

CATALOGO PRODUCTS  
PRODOTTI CATALOGUE

ITALIAN VACUUM MAKERS



ADVANCED VACUUM SYSTEM

“Da qui nasce il nostro prodotto...  
E di conseguenza il nostro impegno  
con il cliente”

*Our product is born here, and  
consequently our commitment  
towards our customers too!*



*Sembra ieri, e sono passati più di  
30 anni... tanti ma non sufficienti  
per dare spazio a tutte le nuove idee*

*Davide Lavezzini*

*it seems like yesterday but more than 30 years have gone... it seems quite a  
lot of time but not enough to develop all the new ideas*

*Davide Lavezzini*



Nel mondo anche con lo sport  
*In the world with sport too*





---

**CONFEZIONATRICI AD  
ASPIRAZIONE ESTERNA**

**VACUUM SEALERS**

**MACHINES SOUS VIDE À  
ASPIRATION EXTÉRIEURE**

**ENVASADORAS  
ASPIRACIÒN EXTERIOR**

**GERÄTE OHNE KAMMER**

**HOMES Series** PAG 6



FRESH

**MINI Series** PAG 8



MINI MINI  
MINI BIG

**ECONOMY Series** PAG 10



SMALL  
ELIX  
MEDIUM

**PROFESSIONAL Series** PAG 14



EASY PACK  
MINI PACK

**PROFESSIONAL PLUS Series** PAG 16



1000 B  
2000  
2000 S

**THERMOSEALER Series** PAG 19



LX 320  
LX 420

LEGENDA SIMBOLI:



Costruito nel rispetto dell'ambiente  
*Environment friendly manufactured*  
*Construit en respectant l'environnement*  
*Fabricado respetando el ambiente*  
*Umweltfreundliche Herstellung*



Ideale per supermercati e macellerie  
*Suitable for supermarkets and butcheries*  
*Idéal pour supermarchés et boucheries*  
*Ideal para supermercados y carnicerías*  
*Ideal für Supermärkte und Metzgereien*



Ideale per alimentari e gastronomie  
*Suitable for food shops and delicatessen*  
*Idéal pour alimentaires et gastronomies*  
*Ideal para detallantes y gastronomías*  
*Ideal für lebensmittelverarbeitende Betriebe und Gastronomie*



Ideale per ristoranti  
*Suitable for restaurants*  
*Idéels pour restaurants*  
*Ideal para restaurantes*  
*Ideal für Restaurants*



**FRESH**

Modello model modèles modelo Modelle	Struttura structure structure estructura Struktur	Dim. d'ingombro overall dimension dim. d'encombrement dimensiones Abmessungen	Barra saldante sealing bar barre de soudure barra soldante Schweißleiste	Pompa del vuoto vacuum pump pompe du vide bomba de vacío Vakuumpumpe	Peso weight poids peso Gewicht	Assorbimento absorption absorption consumo Aufsaugen	Tensione voltage voltage tensión Spannung
FRESH	abs	380x180x80 H	mm 300	Q= 10/12 LTmin	KG 2.3	W190	230 V/50-60 Hz

## FRESH



Confezionatrice sottovuoto automatica in ABS. Pensata per un utilizzo domestico e realizzata con caratteristiche e standard funzionali di livello semi-professionale, soddisfa a pieno tutte le necessità di confezionamento e di protezione degli alimenti di qualsiasi nucleo familiare.

Può realizzare "vuoto in sacchetto" su prodotti asciutti e "vuoto in contenitori" per liquidi e salse.



This is the right vacuum packing machine for domestic use, with its ABS external structure and a semi-professional level of practical features. It completely satisfies all those small family's needs related to food packing and protection. Fresh can works two different ways: by making vacuum inside bags or vacuum in external recipients conceived for liquids/sauces.



Machines à emballer sous vide automatique en ABS. Pensée pour un usage ménager, et réalisée avec caractéristiques et standards fonctionnels de niveau semi-professionnel, elle est en mesure de satisfaire toutes les nécessités de conditionnement et de protection des aliments pour toutes typologies de particuliers. Elle est en mesure de réaliser le «vide en sachet» sur produits secs et «vide en recipients» pour liquides et sauces.



Envasadora al vacío automática de plástico ABS. Pensada por un uso doméstico y realizada con características y niveles funcionales semi-profesionales, puede satisfacer cualquier necesidad de envasamiento y protección de los productos de cualquier familia. Puede hacer el vacío dentro de las bolsas (envasando productos sólidos, sin humedad) y vacío en vasos, envasando líquidos y salsas.



Automatisches Vakuum-Verpackungsgerät aus ABS-Kunststoff. Entwickelt für den Heimgebrauch verfügt dieses Vakuumiergerät über Eigenschaften und Anwendungen auf beinahe professioneller Ebene und erfüllt somit alle Anforderungen der Lebensmittel- und Schutzverpackungen jedes Haushaltes. Das Gerät ist für die Vakuum-Verpackung von trockenen Produkten in Beuteln geeignet und ebenso für die Vakuum-Verpackung von Flüssigkeiten und Saucen in den entsprechenden Behältern.

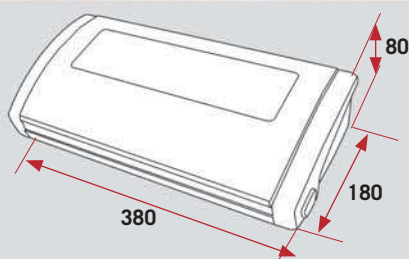

Alloggiamento per sacchetti in rullo  
Roller bags seat

# MINI SERIES



**MINI MINI**



**MINI BIG**



Modello model modèles modelo Modelle	Struttura structure structure estructura Struktur	Dim. d'ingombro overall dimension dim. d'encombrement dimensiones Abmessungen	Barra saldante sealing bar barre de soudure barra soldante Schweißleiste	Pompa del vuoto vacuum pump pompe du vide bomba de vacío Vakuumpumpe	Peso weight poids peso Gewicht	Assorbimento absorption absorption consumo Aufsaugen	Tensione voltage voltage tensión Spannung
MINI MINI	inox	370x260x130 H	mm 350	Q= 20/24 LTmin	KG 8	W250	230 V/50-60 Hz
MINI BIG	inox	470x260x130 H	mm 450	Q= 20/24 LTmin	KG10	W270	230 V/50-60 Hz

## MINI MINI / MINI BIG



Confezionatrici sottovuoto Semi automatiche, analogiche, in acciaio inox. Rappresentano il primo passo nel mondo professionale del confezionamento degli alimenti. Il piccolo negozio o il punto vendita al dettaglio rappresentano il target di riferimento dei modelli presenti all'interno della gamma MINI SERIES. Possono realizzare il vuoto in sacchetti oppure in contenitori specifici per liquidi o prodotti delicati. L'estrema robustezza dell'apparecchiatura e l'elevata solidità costruttiva rappresentano il punto di forza della propria gamma di riferimento



Machines à emballer sous vide semi automatiques, analogiques et en acier inox. Elles représentent le premier pas vers le monde du conditionnement professionnel. Le target de référence des modèles de cette gamme est le petit magasin, ou bien le point de vente. Ces appareils sont en mesure de réaliser le «vide en sachet», ou bien en «recipients spécifiques» pour liquides ou produits délicats. La structure robuste et la grande solidité représentent le vrai point de force de cette ligne de sousvideuses.



Envasadoras al vacío semi automáticas, con panel de mandos mecánico y mueble de acero inox. Son el primer paso hacia el mundo profesional del empaquetamiento de los alimentos. La pequeña tienda alimenticia o el pequeño detallante son el segmento de mercado al cual se dirige la gama MINI SERIES. Pueden hacer el vacío dentro de las bolsas (envasando productos sólidos, sin humedad) y vacío en vasos, envasando líquidos y salsas. La gran solidez de la máquina y la solidez de la estructura representan el punto de fuerza de la gama de referencia.



Halbautomatische Vakuum-Verpackungsgeräte mit analoger Steuerung, aus rostfreiem Stahl. Diese Geräte stellen den ersten Schritt in der professionellen Lebensmittelverpackung dar. Kleine Lebensmittelhändler und Einzelhändler sind die Zielgruppe für diese Modelle der Produktserie MINI-SERIES. Diese Geräte sind für die Vakuum-Verpackung von trockenen Produkten in Beuteln geeignet und ebenso für die Vakuum-Verpackung von Flüssigkeiten und empfindlichen Produkten in den entsprechenden Behältern. Die extreme Robustheit der Geräte und deren solide Konstruktion zeichnen diese Gruppe innerhalb der Produktlinie aus.



Semi-automatic and analogical vacuum packing machines totally built in stainless steel. They represent the first step in the professional field of the food packaging. MINI SERIES range of models is surely the most suitable one for small shops and retailers. MINI SERIES machines can work two different ways: by making vacuum inside bags or vacuum in external recipients conceived for liquids/ sauces. Their solidity of their structure is no doubt one the most salient feature of this range.



Mini mini

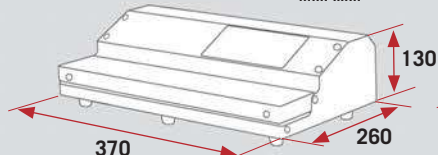

Mini big

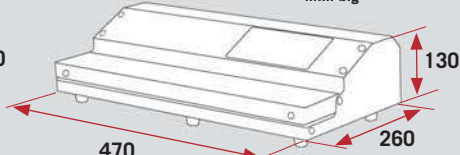

INOX CE



# ECONOMY SERIES



SMALL



ELIX



MEDIUM

Modello model modèles modelo Modelle	Struttura structure structure estructura Struktur	Dim. d'ingombro overall dimension dim. d'encombrement dimensiones Abmessungen	Barra saldante sealing bar barre de soudure barra soldante Schweißleiste	Pompa del vuoto vacuum pump pompe du vide bomba de vacío Vakuumpumpe	Peso weight poids peso Gewicht	Assorbimento absorption absorption consumo Aufsaugen	Tensione voltage voltage tensión Spannung
SMALL	inox	370x280x170 H	mm 350	Q= 20/24 LTmin	KG 8	W250	230 V/50-60 Hz
ELIX	inox	420x280x170 H	mm 400	Q= 20/24 LTmin	KG 9	W270	230 V/50-60 Hz
MEDIUM	inox	520x280x170 H	mm 500	Q= 40/48 LTmin	KG 12	W350	230 V/50-60 Hz

## SMALL / ELIX / MEDIUM



Confezionatrici sottovuoto automatiche digitali in acciaio inox. Rappresentano da oltre un decennio una conferma di qualità e durata nel tempo, siglata da oltre 15.000 apparecchi operanti sul mercato.

La robusta struttura inox e l'elettronica digitale con possibilità di selezione del ciclo manuale/automatico rendono "l'economy series" la risposta più efficace per la distribuzione degli alimenti al dettaglio.

- vuoto in sacchetto
  - vuoto in contenitori
  - vuoti in sacchetti multipli (per il modello medium)
- L'indicazione del livello di vuoto ci consente di seguire le varie fasi evolutive del processo di confezionamento.



Envasadoras al vacío con panel de mandos digital y automático, de acero inox.

Representan, desde más que una década, una garantía de calidad y duración en el tiempo, confirmada desde más de 15.000 máquinas trabajando en el mercado.

La sólida estructura inox y la electrónica digital con la posibilidad de elegir el ciclo de trabajo manual/automático hacen que la "economy series" sea la respuesta más eficaz a la venta de los alimentos al por menor.

- Vacío en bolsas
- Vacío en vasos
- Vacío en más bolsas en el mismo tiempo

La muestra del nivel de vacío nos permite seguir paso a paso las diferentes etapas del ciclo de trabajo.



Fully automatic vacuum packing machines with digital control panel totally built in stainless steel.

With more than 15000 sets on the market, ECONOMY series has been a constant confirmation of quality and reliability for over a decade. Their solid stainless steel structure and the digital control panel with working cycle selection "manual/automatic" make this series the most successful solution for the retail distribution of food.

- Vacuum in bags
- Vacuum in external recipients
- Vacuum in more bags at the same time (For "Medium" machine)

The vacuum gauge gives the possibility to check the different phases of the working cycle.

Machines à emballer sous vide automatiques digitales, en acier inox.

Depuis une dizaine d'années elles représentent une confirmation de qualité et durée dans le temps, témoinnée par plus de 15.000 appareils vendus sur le marché.

La structure robuste en inox, et l'électronique digitale avec possibilité de choisir entre cycle manuel/automatique rendent la «Economy Series» la réponse plus efficace pour la distribution des aliments.

- Vide en sachets
- Vide en recipients
- Vide en sachets multiples (pour le modèle Medium)

L'indication du niveau de vide, permet de suivre les phases d'évolution du conditionnement.



Automatische Vakuum-Verpackungsgeräte mit digitaler Anzeige, aus rostfreiem Stahl gefertigt. Diese Maschinen stellen seit über einem Jahrzehnt eine Bestätigung für lang anhaltende Qualität dar, mit bisher über 15.000 verkauften Geräten. Die robuste Stahl-Struktur des Gehäuses und die digitale Elektronik mit Auswahlmöglichkeit von manuellem oder automatischem Zyklus machen die ECONOMY SERIES zur effektiven Antwort auf alle Verpackungsfragen in der Lebensmitteleinzelhandelsbranche.

- Vakuumierung im Beutel
- Vakuumierung im Behälter
- Vakuumierung in mehreren Beuteln gleichzeitig (Modell „Medium“)

Die Anzeige des erreichten Vakuum-Niveaus ermöglicht, die verschiedenen Phasen des Verpackungs-Prozesses zu verfolgen.

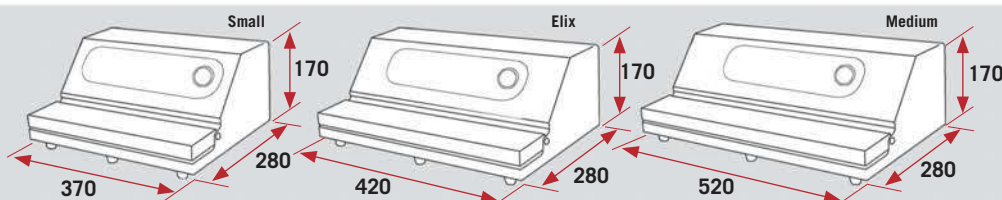

INOX | CE



# ECONOMY SERIES



Small



Elix



Medium

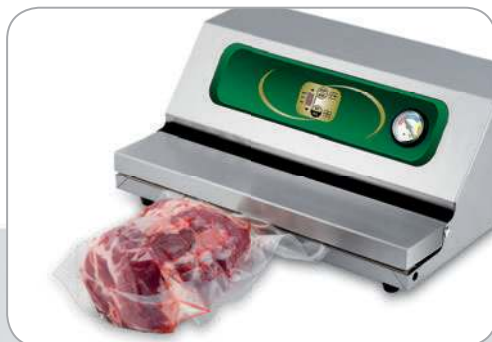

## SMALL / ELIX / MEDIUM

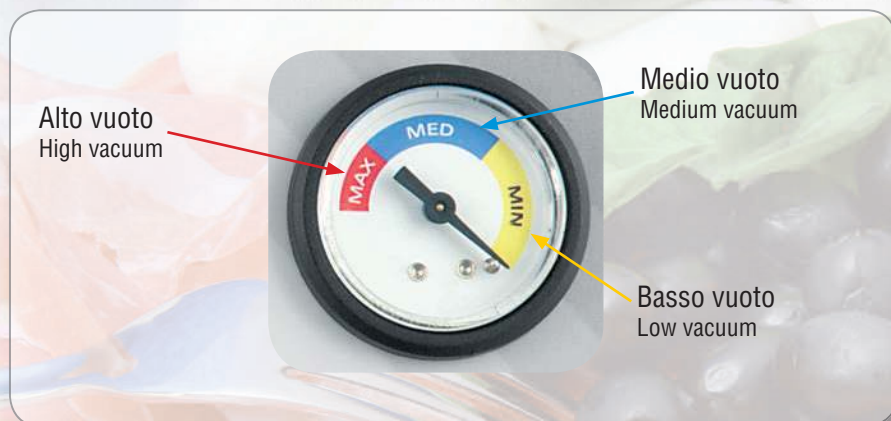
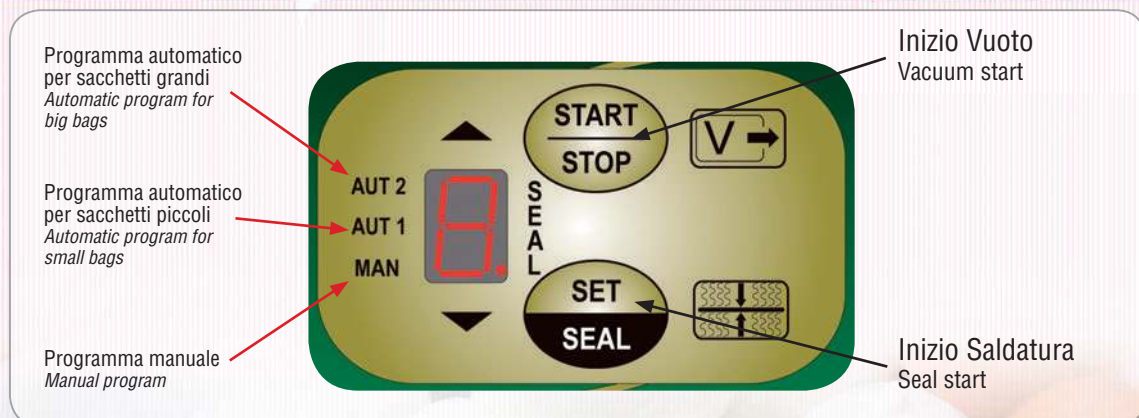
Pompa del vuoto  
Vacuum pump

# PROFESSIONAL SERIES



**EASY PACK**



**MINIPACK**

Modello model modèles modelo Modelle	Struttura structure structure estructura Struktur	Dim. d'ingombro overall dimension dim. d'encombrement dimensiones Abmessungen	Barra saldante sealing bar barre de soudure barra soldante Schweißleiste	Pompa del vuoto vacuum pump pompe du vide bomba de vacío Vakuumpumpe	Peso weight poids peso Gewicht	Assorbimento absorption absorption consumo Aufsaugen	Tensione voltage voltage tensión Spannung
<b>EASY PACK</b>	inox	370x280x180 H	mm 350	Q= 40/48 LTmin	KG 11	W300	230 V/50-60 Hz
<b>MINIPACK</b>	inox	420x310x180 H	mm 400	Q= 40/48 LTmin	KG 13	W350	230 V/50-60 Hz

## EASY PACK / MINIPACK



Confezionatrici sottovuoto automatiche digitali in acciaio inox.

Determinano il passaggio di target della clientela di riferimento che dal negozio al dettaglio si avvicina al supermercato e alla distribuzione organizzata.

Le apparecchiature "professional series" dispongono di tutti gli automatismi/ciclo possibili rendendo queste confezionatrici rapide ed efficaci per ogni tipologia di confezione. Sono in grado di operare in sacchetti, contenitori in polycarbonato e in sacchetti multipli. L'elevata capacità della pompa del vuoto le rende estremamente veloci nella fase di confezionamento



Machines à emballer sous vide automatiques, digitales, en acier inox.

Elles déterminent le passage de target de clientèle qui, dès le magasin s'approche aux supermarchés et à la distribution plus organisée.

Les appareils « Professional series » disposent de tous systèmes automatisés, ce qui rend ces sousvideuses rapides et très efficaces pour toutes typologies de conditionnement. Elles sont en mesure de travailler dans le sachet, recipients et sachets multiples. De plus, il s'agit d'appareils très rapides pendant le cycle de conditionnement, grâce à la grande puissance de la pompe.



Envasadoras al vacío con panel de mandos digital y automático, de acero inox. El segmento de mercado al cual se dirige esta gama pasa del pequeño detallante al supermercado y a la distribución organizada. Las máquinas de la serie profesional llevan todos los automatismos posibles del ciclo, que hacen que estas envasadoras sean rápidas y eficaces para cualquier envase. Pueden envasar bolsas y vasos de polycarbonato. La potencia de la bomba de vacío hace que estas máquinas hagan el vacío muy rápidamente.



Automatische Vakuum-Verpackungsgeräte mit digitaler Anzeige, aus rostfreiem Stahl gefertigt. Die Zielgruppe für diese Geräte ist besonders weit gefächert und reicht vom Einzelhandel über den Supermarkt bis hin zu Lebensmittelketten. Die Geräte der „Professional Series“ sind mit allen Automatisierungen des Zyklus ausgestattet und bieten sich daher als schnelle und effektive Verpackungslösung für alle Varianten an: Die Geräte sind sowohl in der Lage Verpackungen in Beuteln, als auch Containern aus Polycarbonat und in mehreren Beuteln zu erstellen. Die Hochleistungs-Vakuumpumpe macht die Maschinen besonders schnell in der Verpackungsphase.



Professional vacuum packing machines with digital control panel totally built in stainless steel. This series approaches to supermarkets and large scale retail trade.

They can be used to pack the most diversified types of packing, as "PROFESSIONAL SERIES" line offers all the necessary working cycle automatism for this purpose.

These appliances grant both vacuum in one or more bags at the same time and vacuum in external recipients; moreover, thanks to their highly performing vacuum pumps they enable extremely quick working cycles.



Apertura automatica della piastra a fine ciclo di lavoro  
Automatic opening

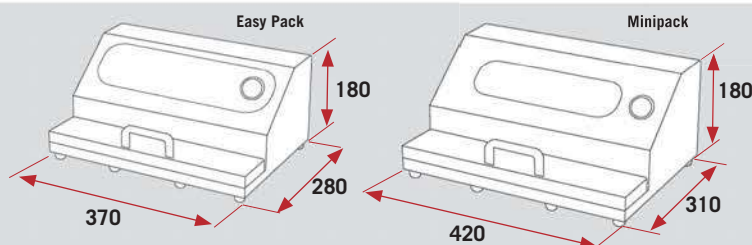

INOX CE



# PROFESSIONAL PLUS SERIES



1000 B



2000



2000 S

**OIL**

Modello model modèles modelo Modelle	Struttura structure structure estructura Struktur	Dim. d'ingombro overall dimension dim. d'encombrement dimensiones Abmessungen	Barra saldante sealing bar barre de soudure barra soldante Schweißleiste	Pompa del vuoto vacuum pump pompe du vide bomba de vacío Vakuumpumpe	Peso weight poids peso Gewicht	Assorbimento absorption absorption consumo Aufsaugen	Tensione voltage voltage tensión Spannung
1000 B	inox	470x380x210 H	mm 450	Q=6/7.2 m <sup>3</sup> h-OIL	KG 22	W450	230 V/50-60 Hz
2000	inox	520x380x210 H	mm 500	Q=6/7.2 m <sup>3</sup> h-OIL	KG 23	W500	230 V/50-60 Hz
2000 S	inox	570x380x210 H	mm 550	Q=6/7.2 m <sup>3</sup> h-OIL	KG 25	W550	230 V/50-60 Hz

## 1000 B / 2000 / 2000 S



Confezionatrici sottovuoto automatiche digit, in acciaio inox, a bagno d'olio. Rappresentano il top di gamma delle confezionatrici ad estrazione esterna. La struttura super rinforzata, gli automatismi del ciclo sono totalmente di serie, mentre le pompe dispongono di lubrificazione forzata che le rende utilizzabili anche per cicli di lavoro giornalieri ininterrotti. Possono operare in sacchetti, contenitori in policarbonato, e sacchetti multipli garantendo risultati ottimali su qualsiasi prodotto dovessero operare. La serie "Professional Plus" nata agli inizi degli anni 80, arrivata alla 3° serie di produzione, ha rappresentato per anni nel mondo un importante riferimento di settore.

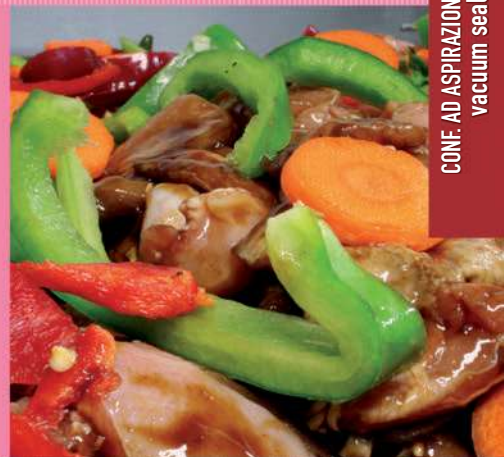
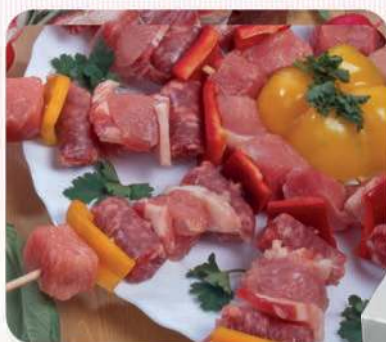

Professional vacuum packing machines with digital control panel totally built in stainless steel and equipped with oil pumps. They are the top of the whole range of vacuum packing machines by external suction. Their strengthened structure, their working cycle automatism in series and their forced lubrication pumps make them particularly fit for long lasting daily working sessions. "PROFESSIONAL PLUS" series can make vacuum in one or more bags at the same time and vacuum in external recipients, with the best possible results ever, in any occasion. Born in the early 80's, this range has now arrived to its 3rd newly conceived series and has always been an important reference for the whole sector.



Automatische Vakuum-Verpackungsgeräte mit digitaler Anzeige, aus rostfreiem Stahl gefertigt mit Ölbad Pumpe. Diese Modelle stellen die Spitzengruppe der Produktpalette an Vakuumgeräten ohne Kammer dar. Die zusätzliche verstärkte Struktur und der automatische Zyklus werden standardmäßig in Serie produziert, während die Pumpen mit spezieller Schmierung ausgestattet sind, die auch lange durchgehende Laufzeiten ermöglichen. Die Geräte sind sowohl in der Lage Vakuum-Verpackungen in Beuteln, sowie Containern aus Polycarbonat und in mehreren Beuteln gleichzeitig mit optimalen Ergebnissen bei allen Produktarten zu erstellen. Seit den frühen 80er Jahren ist diese nun bereits die 3. Serien und stellt in der Branche eine wichtige Referenz dar.



Machines à emballer sous vide automatiques, digitales en acier inox, avec pompe à huile. Elles représentent le top de la gamme des sousvideuses à aspiration extérieure. La structure super renforcée et l'automatisation du cycle sont déjà prévus de série; les pompes disposent de lubrification forcée, ce qui les rend utilisables même pour cycles de travail continus. Elles sont en mesure de travailler en sachets, récipients et sachets multiples en garantissant excellents résultats pour toutes les typologies de produits. la Série Professional Plus, née au début des années '80, la gamme est arrivée à la 3<sup>e</sup> série de production, et représente une importante référence de marché, depuis des années.



Envasadoras al vacío con panel de mandos digital y automático, de acero inox y con bomba de vacío con aceite. Son lo mejor entre las envasadoras al vacío por aspiración externa. La estructura resolidada, los automatismos del ciclo son de serie. Las bombas de vacío, siendo con aceite, pueden trabajar todo el día seguido. Pueden envasar bolsas, vasos de policarbonato y también más bolsas en el mismo tiempo, garantizando óptimos resultados para cualquier producto. Esta gama nació en los primeros años 80 y llegó a la 3<sup>ª</sup> serie de producción, representando un importante punto de referencia en el sector, en todo el mundo.

1000 B

2000

2000 S

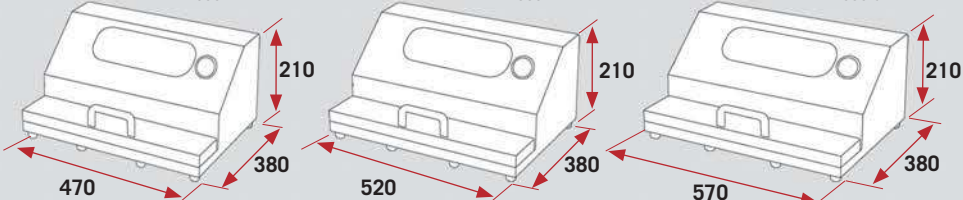

INOX ICE



# PROFESSIONAL PLUS SERIES



Pompa del vuoto  
Vacuum pump

Filtro aria - Air filter

Olio - Oil



## LX 320 / LX 420



TERMOSALDATICI PER SACCHETTI di differenti tipologie di materiali (polietilene, nylon, alluminio). L'apparecchiatura estremamente compatta e maneggevole è dotata di TIMER per termosaldare differenti spessori, trovando largo impiego nel settore food (ortofrutta, panifici, pasticcerie etc.) e non food (ferramenta, ricambistica, settore elettronico etc.)



No Food



Food



Termoschelleuses pour sachets de différents typologies de matériels (polyéthylène, nylon, aluminium). L'appareil, très compact et maniable, est équipé de timer pour termosouder différents épaisseurs ; utilisé soit dans le secteur alimentaire (des fruits et légumes, boulangeries, pâtisseries, etc..) soit non alimentaire (quincaillerie, pièces détachées, secteur électronique, etc..).



Thermoschweißgeräte für Beutel aus verschieden Materialien (Polyethylen, Nylon, Aluminium). Das Gerät ist kompakt und leicht in der Handhabung, ausgestattet mit Timer zur Verschweißung unterschiedlicher Stärken. Es findet weit verbreitete Anwendung in der Lebensmittelbranche (Obst und Gemüse, Backwaren, Süßwaren usw.) und wird auch in anderen Bereichen eingesetzt (Hardware, Ersatzteile, Elektronik etc.).



TERMOSOLDADORA para diferentes tipos de bolsas (polietileno, nilòn, aluminio). El aparato, muy compacto y cómodo, tiene un temporizador para termosoldar diferentes grososres, y tiene un gran utilizo sea en el sector alimentar (sector hortofruticola, panaderias, pastelerias...) sea en sectores no alimenticios (ferreterias, recambios, sector electrónico...)

THERMOSEALERS to be used with bags made of different materials (polyethylene, nylon, aluminium). This extremely solid but handy device is TIMER equipped in order to seal bags with different thickness and make it fit to be used in both food (Groceries, baker's, confectioner's...) and non-food (Ironmonger's shops, spare parts, electronics...) sectors.



Modello model modèles modelo Modelle	Dim. d'ingombro overall dimension dim. d'encombrement dimensiones Abmessungen	Barra saldante sealing bar barre de soudure barra soldante Schweißleiste	Peso weight poids peso Gewicht	Assorbimento absorption absorption consumo Aufsaugen	Tensione voltage voltage tensión Spannung
LX 320	450x80x260 (open)	mm 320	KG 3,7	W 300	230 V/50-60 Hz
LX 420	550x80x260 (open)	mm 420	KG 4,4	W 400	230 V/50-60 Hz



---

**CONFEZIONATRICI A  
CAMPANA DA BANCO**

**TABLE TOP  
VAC PACKERS**

**MACHINES SOUS VIDE À  
CLOCHE DE TABLE**

**ENVASADORAS A  
CAMPANA SOBREMESA**

**KAMMERGERÄTE**



NEW Series

PAG 22



MYCRA  
UNIVERSAL  
OPTIMA  
UNICA  
SUPREMA

PRESTIGE Series

PAG 26



DG 25  
DG 30  
DG 35  
DG 40  
DG 45

TOP Series

PAG 30



START  
BABY  
SPEEDY  
JOLLY  
BOXER 45  
BOXER DUO  
BIG BOXER  
BOXER 80

KRISTAL Series

PAG 36



KRISTAL 330  
KRISTAL 430



LEGENDA SIMBOLI:



Costruito nel rispetto dell'ambiente  
*Environment friendly manufactured*  
*Construit en respectant l'environnement*  
*Fabricado respetando el ambiente*  
*Umweltfreundliche Herstellung*



Ideale per supermercati e macellerie  
*Suitable for supermarkets and butcheries*  
*Idéal pour supermarchés et boucheries*  
*Ideal para supermercados y carnicerías*  
*Ideal für Supermärkte und Metzgereien*



Ideale per alimentari e gastronomie  
*Suitable for food shops and delicatessen*  
*Idéal pour alimentaires et gastronomies*  
*Ideal para detallantes y gastronomías*  
*Ideal für Lebensmittelverarbeitende Betriebe und Gastronomie*



Ideale per ristoranti  
*Suitable for restaurants*  
*Idéal pour restaurants*  
*Ideal para restaurantes*  
*Ideal für Restaurants*

## NEW SERIES



SUPREMA



500



UNICA

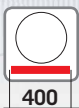

400



MYCRA



250



OPTIMA



350



UNIVERSAL



300

APERTURA  
CAMPANA MANUALE  
MANUAL BELL  
OPENING

Modello model modèles modelo Modelle	Struttura structure structure estructura Struktur	Dim. d'ingombro overall dimension dim. d'encombrement dimensiones Abmessungen	Dimensioni camera size of the chamber dim. de la chambre dim. de la càmara Kammergröße	Barra saldante sealing bar barre de soudure barra soldante Schweißbleiste	Pompa del vuoto vacuum pump pompe du vide bomba de vacío Vakuumpumpe	Peso weight poids peso Gewicht	Assorbimento absorption absorption consumo Aufsaugen	Tensione voltage voltage tensión Spannung
MYCRA	inox	320X500X270 H	260X300X120 H	mm 250	Q= 6/7.2 m <sup>3</sup> h-OIL	kg 25	W 350	230 V/50-60 Hz
UNIVERSAL	inox	370X530X270 H	310X350X120 H	mm 300	Q= 6/7.2 m <sup>3</sup> h-OIL	kg 32	W 350	230 V/50-60 Hz
OPTIMA	inox	420X530X400 H	360X400X190 H	mm 350	Q= 8/9.6 m <sup>3</sup> h-OIL	kg 40	W 450	230 V/50-60 Hz
UNICA	inox	470X550X430 H	410X450X220 H	mm 400	Q= 12/14.4 m <sup>3</sup> h-OIL	kg 55	W 900	230 V/50-60 Hz
SUPREMA	inox	560X610X410 H	500X460X200 H	mm 500	Q= 12/14.4 m <sup>3</sup> h-OIL	kg 60	W 950	230 V/50-60 Hz

# MYCRA / UNIVERSAL / OPTIMA / UNICA / SUPREMA



Rappresentano la linea d'ingresso al mondo professionale del confezionamento a campana. Ideali per svariati settori d'applicazione si caratterizzano in particolare per l'ottima qualità costruttiva, le elevate prestazioni e per un posizionamento economico di mercato estremamente vantaggioso. Dotate di un'elettronica di precisione ma nello stesso tempo di semplice utilizzo, sono in grado di operare con sacchetti di svariate tipologie, in contenitori esterni e addirittura in aspirazione esterna a mezzo buste goffrate.

Totalmente in acciaio inox, dotate di vasche stondate e prive di saldature interne con barre saldanti estraibili di serie sono in grado di garantire alla piccola-media azienda super prestazioni al miglior prezzo di mercato in assoluto.



CONF. A CAMPANA DA BANCO  
table top vac packers



## VACUUM TESTER

Rilevatore digitale di vuoto in campana

Vacuum digital detector

Détecteur digitale du vide dans la chambre

Aparato digital para medir el vacío en campana

Digitales Vermessungsgerät für Vakuum im Kammer

Dimensioni d'ingombro / overall dimension  
dim. d'encombrement / dimensiones / Größe

mm 65X23X110 H



Elles représentent la ligne d'entrée dans le secteur professionnel du conditionnement dans la cloche. Idéales pour les différents secteurs d'usage, elles se caractérisent en particulier par l'excellente qualité et les performances, ainsi que pour une position de marché très économique et vraiment avantageuse.

Equipées d'une composant électronique de précision, mais au même temps très simple à utiliser, elles sont en mesure de travailler avec sachets des différentes typologies, dans récipients externes et même en aspiration extérieure en utilisant les sacs goffrés.

Fabriquées entièrement en acier inox, équipées de cuves avec coins rebondis et sans soudures intérieures avec barres extractible de série, elles garantissent à la petite-moyenne Entreprise des super performances, au meilleur prix de marché.



Ciclo di vuoto in camera  
Working cycle inside vacuum chamber



Esta es la gama de entrada en el mundo profesional de las envasadoras de campana. Estas maquinas son ideales para muchos sectores y se caracterizan por la optima calidad constructiva, por el gran rendimiento y gracias al precio ventajoso que le coloca muy bien en el mercado.

Tienen una placa electronica precisa y muy sencilla para utilizarse, pueden trabajar con bolsas de diferentes tipos, pueden hacer el vacío en cubetas externas y tambien por aspiración externa, utilizando bolsas gofradas.

Todas de acero inox, con depositos embutidos con angulos redondeados, con barras soldantes completamente extraibles de serie, estas maquinas pueden garantizar a la pequeña - media empresa trabajos espectaculares con el mejor precio del mercado.



Ciclo di vuoto in aspirazione esterna  
Working cycle by external suction



Diese Produktgruppe bietet den ersten Schritt in der Welt des professionellen Verpackens mit Kammergeräten. Ideal für eine Vielzahl von Anwendungsbereichen, heben sich diese Geräte insbesondere durch ihre hervorragende Verarbeitungsqualität, das hohe Leistungs-niveau und ihre äußerst attraktive wirtschaftliche Marktpositionierung hervor.

Ausgestattet mit präzisen elektronischen Komponenten, aber dennoch einfach zu bedienen, sind diese Geräte in der Lage in verschiedenen Stärken von Beuteln innerhalb der Kammer, in externen Behältern und sogar außerhalb der Kammer durch externe Absaugung in strukturierten Beuteln zu Vakuumieren.

Die Geräte sind vollkommen aus Edelstahl gefertigt und verfügen über Tanks mit abgerundeten Ecken und frei von inneren Schweißnähte sowie herausnehmbare Schweißbalken. Aufgrund der hervorragenden Leistung und des ausgezeichneten Marktpreises sind diese Vakuumgeräte somit ideal für kleine und mittlere Unternehmen.

These 3 models are meant to be the entry into the field of professional vacuum packaging with chamber machines.

Suitable for several sectors of employment, these three models are easily recognizable for their top quality structure, their extremely high work capacity and, above all, for their amazing and extremely advantageous price level. They have an accurate but simple electronic device. They can work with different kinds of vacuum bags, make vacuum in external recipients and even in embossed bags by external suction. Totally stainless steel built and equipped with printed vacuum chambers and totally removable sealing bars, these three models can offer their amazing services at the best price ever on the market.



Mycra

Universal

Optima

Unica

Suprema

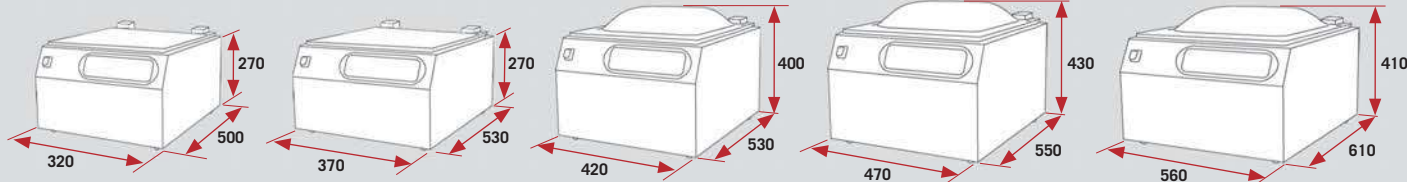

## PANNELLO COMANDI / control panel

### Accensione / Spegnimento confezionatrice

Switch on / switch off of  
the vacuum packaging  
machine

### - Modifica parametri vuoto / saldatura

- used to modify vacuum /  
sealing parameters

1. Settaggio % di vuoto
2. Settaggio tempo di saldatura
3. Attivazione funzione saldatura rapida
4. Attivazione funzione VAC STOP:  
interruzione anticipata del ciclo di vuoto

1. Setting of the vacuum percentage
2. Setting of the sealing time
3. Activation of RAPID SEALING, if you push the  
button once
4. Activation of VAC STOP FUNCTION (stop  
in advance the vacuum cycle) if you push the  
button twice

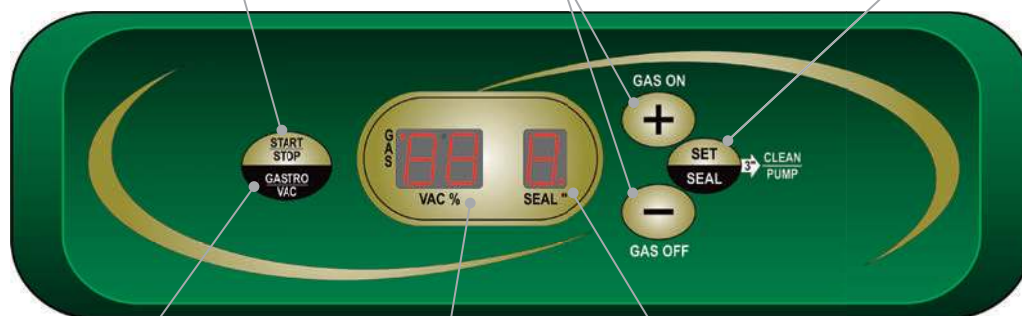

Funzione di vuoto in  
continuo, per aspirazione  
in contenitori gastronorm  
*nonstop vacuum function  
done with suction in gastro  
bowls*

Definizione della percen-  
tuale di vuoto raggiunta in  
camera  
*vacuum level reached in  
the chamber*

Definizione tempo di  
saldatura (espresso in  
secondi)  
*sealing time (in seconds)*



UNICA

# MYCRA / UNIVERSAL / OPTIMA UNICA / SUPREMA



CONF. A CAMPANA DA BANCO  
table top vac packers

## STANDARD FUNCTIONS



**Pannello comandi digitale con vuoto in percentuale (VAC-STOP- RAPID SEALING)**  
*Simplified digitale control panel (one program- vac stop- Rapid sealing)*



**Vasca inox con angoli stondati senza saldature interne**  
*Entirely printed stainless steel vacuum chamber, with internal round corners*



**Barre saldanti estraibili**  
*Removable sealing bars*



**Connessione per attacco gastrovac**  
*Connection for the gastrovac system*



**Carter apribile a 90°**  
*90° openable carter*

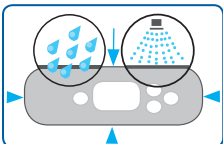

**Pannello comandi a totale tenuta contro umidità**  
*Waterproof control Panel*



**Set tavole di riempimento in polietilene**  
*Polyethylene filling squares set*

## OPTIONALS



**Carrello supporto macchina**  
*Charriot on wheels*

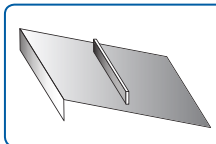

**Piano inclinato per liquidi**  
*Inclined plane for liquids*



**Tensione e frequenza speciale**  
*Voltage and speciale frequency*



INOX | CE

# PRESTIGE SERIES



DG 25



250



DG 30



300



DG 35



350



DG 40



400



DG 45



450

Modello model modèles modelo Modelle	Struttura structure structure estructura Struktur	Dim. d'ingombro overall dimension dim. d'encombrement dimensiones Abmessungen	Dimensioni camera size of the chamber dim. de la chambre dim. de la càmara Kammergröße	Barra saldante sealing bar barre de soudure barra soldante Schweißleiste	Pompa del vuoto vacuum pump pompe du vide bomba de vacío Vakuumpumpe	Peso weight poids peso Gewicht	Assorbimento absorption absorption consumo Aufsaugen	Tensione voltage voltage tensión Spannung
DG 25	inox	360x400x400 H	260x300x160 H	mm 250	Q= 6/7.2 m <sup>3</sup> h-OIL	Kg 32	W 350	230 V/50-60 Hz
DG 30	inox	410x460x420 H	310x350x190 H	mm 300	Q= 8/9.6 m <sup>3</sup> h-OIL	Kg 38	W 400	230 V/50-60 Hz
DG 35	inox	460x500x420 H	360x400x190 H	mm 350	Q= 8/9.6 m <sup>3</sup> h-OIL	Kg 42	W 450	230 V/50-60 Hz
DG 40	inox	510x560x450 H	410x450x220 H	mm 400	Q= 12/14.4 m <sup>3</sup> h-OIL	Kg 58	W 650	230 V/50-60 Hz
DG 45	inox	560x610x450 H	460x500x220 H	mm 450	Q= 20/24 m <sup>3</sup> h-OIL	Kg 62	W 950	230 V/50-60 Hz
					Q= 20/24 m <sup>3</sup> h-OIL	Kg 68	W 950	230 V/50-60 Hz

# DG 25 / DG 30 / DG 35 / DG 40 / DG 45

La linea di confezionatrici a campana da banco "prestige" si rivolge al cliente esigente in termini di qualità, robustezza e performance dell'apparecchiatura. La nuova versione aggiornata ed arricchita di funzioni dispone di tutto quanto sia il meglio per la clientela; a partire dalla regolazione del vuoto in percentuale ai fine di garantire un confezionamento "ad hoc" ..... al sistema autopulente dell'olio che evita l'inquinamento dell'olio lubrificante stesso, al sistema di totale apertura del carter per agevolare in maniera sorprendente la manutenzione nel post vendita. Etc....

Tutte le caratteristiche strutturali e costruttive tengono conto di tre aspetti di base:

- estrema qualità operativa
- affidabilità garantita nel tempo
- totale flessibilità delle apparecchiature a qualsiasi settore venissero applicate

A richiesta del cliente è possibile disporre del sistema di atmosfera modificata, e quadro comandi analogico per "gli amanti della tradizione"



CONF. A CAMPANA DA BANCO  
table top vac packers



La ligne de machines sous vide de table « PERSTIGE » s'adresse au client exigeant pour qualité, structure et performance de l'appareil. La nouvelle version, mise à jour et étoffée de nouvelles fonctionnes, dispose de tout ce qui est mieux pour la clientèle, à partir du réglage du vide en pourcentage qui garantise un conditionnement « ad hoc », le système auto nettoyant de la pompe, qui empêche la pollution de l'huile et, enfin, la complète ouverture du meuble pour faciliter l'entretien et l'après vente.

Tout dans le respect de trois points fondamentales :

- l'excellente qualité opérationnelle ;
- la fiabilité dans le temps ;
- la totale flexibilité des appareils, vers n'importe quel secteur soient utilisés ;

Il est aussi possible d'équiper les machines avec atmosphère modifiée, et panneaux commandes analogique, pour ceux qui préfèrent la tradition.



la gama de envasadoras de campana de sobremesa "prestige" se dirige a los clientes que exigen de la maquina calidad, solidez y rendimiento. La nueva variante, revisada y con funciones añadidas, tiene todo lo que los clientes necesitan; desde la regulación del vacío en porcentaje para garantizar un vacío optimal a la función de autolimpieza de la bomba de vacío que evita la contaminación del aceite, a la posibilidad de abrir totalmente el mueble de la maquina para facilitar muchísimo la manutención técnica.

Todas las características de estructura y de fabricación se fundamentan en 3 principios:

- Gran calidad en el trabajo
- Fiabilidad garantizada en el tiempo
- Total flexibilidad de las maquinas para el utilizo en cualquier sector

Si el cliente lo necesita se puede añadir el opcional de la inyección de gas inerte o el panel de mandos mecanico para los "aficionados a las tradiciones".



"PRESTIGE" range of vacuum packing machines with chamber for desk definitely turns to those extremely demanding customers who look for high quality, solidity and working performance. The latest version of this line is no doubt the best customers might be looking for, thanks to its new available functions: regulation of vacuum phase by sensor to get the most accurate result, self-cleaning pump system to keep pump oil clean as long as possible, the opening carter to make any after sale technical servicing much easier and faster... etc..

All the technical and structure details consider three basic aspects:

- High quality
- Long time granted reliability
- Total flexibility of the different models to operate in the most different sectors of use.

On demand, customers can apply for ATM system and old fashioned analogical control panel.



Die Linie von Verpackungsmaschinen mit Kammer "Prestige" spricht vor allem den anspruchsvollen Kunden in Bezug auf Qualität, Robustheit und Leistung der Geräte an. Die aktualisierte Version wurde mit neuen Funktionen angereichert und bietet dem Kunden jeglichen Komfort in der Bedienung: von der Regulierbarkeit des Vakuums in Prozent, um eine individuelle Verpackung zu garantieren – über den Selbst-Reinigungsmechanismus der Pumpe, der jegliche Verunreinigung mit Schmieröl verhindert – bis hin zur kompletten Öffnung des Gehäuses, um die Wartung der Maschine im After-Sale immens zu erleichtern.

Alle strukturellen und bautechnischen Merkmale berücksichtigt drei grundlegende Aspekte:

- Höchste Qualität im Einsatz
- Zuverlässigkeit im Laufe der Zeit
- Totale Flexibilität der Maschine für alle Branchen und Anwendungsgebiete

Zur Anfrage können die Geräte gerne mit Begasungseinrichtung ausgestattet werden, oder für „Liehaber der Tradition“ auf analoge Steuerung umgestellt werden.



DG 25

DG 30

DG 35

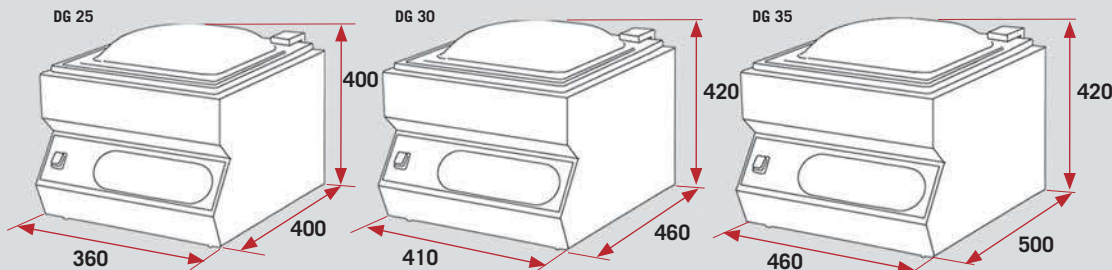

# PRESTIGE SERIES

## PANNELLO COMANDI / control panel

### Accensione / Spegnimento confezionatrice

Switch on / switch off of the vacuum packaging machine

### Funzione Gas Inerte Attivata (LED ACCESO)

Inert gas function on (LED on)

- Modifica parametri vuoto / saldatura / tempo immissione gas
- Attivazione / Disattivazione GAS INERTE
- used to modify vacuum/sealing/gas injection time parameters
- connection/disconnection of inert gas

1. Settaggio % di vuoto
2. Settaggio tempo di saldatura
3. Attivazione funzione saldatura rapida
4. Attivazione funzione VAC STOP: interruzione anticipata del ciclo di vuoto

1. Setting of the vacuum percentage
2. Setting of the sealing time
3. Activation of RAPID SEALING, if you push the button once
4. Activation of VAC STOP FUNCTION (stop in advance the vacuum cycle) if you push the button twice

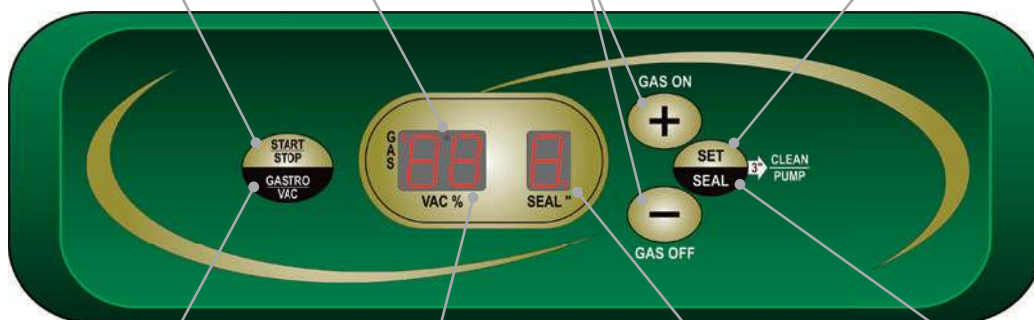

Funzione di vuoto in continuo, per aspirazione in contenitori gastro  
nonstop vacuum function done with suction in gastro bowls

Definizione della percentuale di vuoto raggiunta in camera  
vacuum level reached in the chamber

Definizione tempo di saldatura (espresso in secondi)  
sealing time (in seconds)

Funzione di pulizia olio pompa del vuoto.  
Premendo il tasto per tre secondi a campana chiusa  
pushing the button for three seconds (only when the bell is closed) the cleaning function of the vacuum pump begins

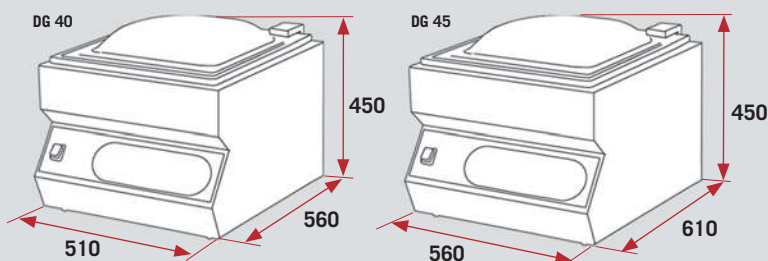



## STANDARD FUNCTIONS



**Pannello comandi digitale con vuoto in percentuale (VAC-STOP- RAPID SEALING)**

*Simplified digitale control panel (one program- vac stop- Rapid sealing)*

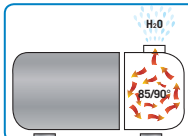

**Sistema autopulizia olio**

*Oil made auto cleaning system*



**Vasca inox con angoli stondati senza saldature interne**

*Entirely printed stainless steel vacuum chamber, with internal round corners*



**Barre saldanti estraibili**

*Removable sealing bars*



**Connessione per attacco gastrovac**

*Connection for the gastrovac system*



**Carter apribile a 90°**

*90° openable carter*

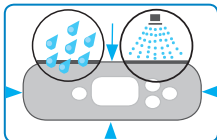

**Pannello comandi a totale tenuta contro umidità**

*Waterproof control Panel*



**Set tavole di riempimento in polietilene**

*Polyethylene filling squares set*

## OPTIONALS



**Predisposizione al gas inerte**

*Arrangement for idle gas*



**Vasca doppia altezza per confezionamento liquidi (DG40)**

*Special double height vacuum chamber to pack liquids (DG40)*



**Pompa Busch**

*Busch Pump*

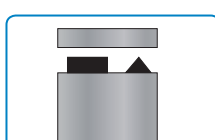

**Taglio Eccedenza**

*Exceeding cutting bar*



**Sistema bloccaggio campana**

*Lid Hook*



**Carrello supporto macchina**

*Charriot on wheels*

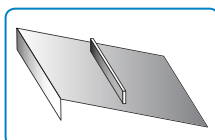

**Piano inclinato per liquidi**

*Inclined plane for liquids*



**Tensione e frequenza speciale**

*Voltage and speciale frequency*

# TROP SERIES



**START**



**BABY**



**SPEEDY**



**JOLLY**



Modello model modèles modelo Modelle	Struttura structure modèles estructura Struktur	Dim. d'ingombro overall dimension dim. d'encombrement dimensiones Abmessungen	Dimensioni camera size of the chamber dim. de la chambre dim. de la càmera Kammergröße	Barra saldante sealing bar barre de soudure barra soldante Schweißleiste	Pompa del vuoto vacuum pump pompe du vide bomba de vacío Vakuumpumpe	Peso weight poids peso Gewicht	Assorbimento absorption absorption consumo Aufsaugen	Tensione voltage voltage tensión Spannung
START LCD	inox	360x400x400 H	260x300x160 H	mm 250	Q= 6/7.2 m <sup>3</sup> h-OIL	Kg 32	W 350	230 V/50-60 Hz
BABY LCD	inox	410x460x420 H	310x350x190 H	mm 300	Q= 8/9.6 m <sup>3</sup> h-OIL	Kg 38	W 400	230 V/50-60 Hz
SPEEDY LCD	inox	460x500x420 H	360x400x190 H	mm 350	Q= 8/9.6 m <sup>3</sup> h-OIL	Kg 42	W 650	230 V/50-60 Hz
JOLLY LCD	inox	510x560x450 H	410x450x220 H	mm 400	Q= 20/24 m <sup>3</sup> h-OIL	Kg 60	W 950	230 V/50-60 Hz

# START / BABY / SPEEDY / JOLLY / BOXER 45 BOXER DUO / BIG BOXER / BOXER 80



Abbiamo prodotto il "Top in assoluto"!!!! Le confezionatrici "Top series" nella nuova versione rappresentano un connubio di qualità, design e prestazioni tali da collocarle con certezza al vertice della categoria.

Oltre alla nuova struttura estremamente robusta e fortemente accattivante abbiamo dotato l'intera linea TOP di un potente microprocessore capace di offrire innumerevoli funzioni di estrema utilità per tutti i settori del food: dalla gestione del vuoto in percentuale, alla gestione programmata del service al sistema autopulente dell'olio, al vuoto esterno a step, ai 20 programmi memorizzabili etc....

Inoltre, a richiesta, una micro stampante potrà etichettare le vostre confezioni migliorando la gestione e lo stoccaggio dei vostri prodotti.



CONF. A CAMPANA DA BANCO  
table top vac packers

**BOXER 80**



**BOXER 45**



**BOXER DUO**



**BIG BOXER**



Modello model modèles modelo Modelle	Struttura structure structure estructura Struktur	Dim. d'ingombro overall dimension dim. d'encombremet dimensiones Abmessungen	Dimensioni camera size of the chamber dim. de la chambre dim. de la càmara Kammergröße	Barra saldante sealing bar barre de soudure barra soldante Schweißleiste	Pompa del vuoto vacuum pump pompe du vide bomba de vacío Vakuumpumpe	Peso weight poids peso Gewicht	Assorbimento absorption absorption consumo Aufsaugen	Tensione voltage voltage tensión Spannung
BOXER 45 LCD	inox	560x610x450 H	460x500x220 H	mm 450	Q= 20/24 m <sup>3</sup> h-OIL	Kg 68	W 950	230 V/50-60 Hz
BOXER DUO LCD	inox	600x560x450 H	500x460x220 H	2x(mm 450)	Q= 20/24 m <sup>3</sup> h-OIL	Kg 70	W 950	230 V/50-60 Hz
BIG BOXER LCD	inox	620x630x450 H	520x520x220 H	mm 500	Q= 20/24 m <sup>3</sup> h-OIL	Kg 80	W 950	230 V/50-60 Hz
BOXER 80 LCD	inox	920x540x450 H	820x420x180 H	2x(mm 400)	Q= 20/24 m <sup>3</sup> h-OIL	Kg 80	W 950	230 V/50-60 Hz



Nuova guarnizione in silicone a ventosa  
New silicone sucker gasket



That's absolutely the real "TOP" product! "TOP SERIES" vacuum packing machines, in their newest and stylish version, are the best union of quality, design and high working performance to be "at the top" of the whole category. Not only these models have a very solid and charming structure, but they also offer very useful devices like the regulation of vacuum phase by sensor, self-cleaning pump system to, "STEP VAC" function to pack liquids and 20 available working programs to customize... It is also possible for customers to apply for a new micro-printer to label bags and therefore obtain a better organization and storage of your products.



Nous disposons vraiment du TOP des produits! Les sousvideuses de la ligne TOP SERIES, dans la nouvelle version, représentent le rencontre de qualité, design et performances, qui permet de les placer au sommet de la catégorie. Les appareils ont été équipés d'une nouvelle structure, plus robuste et captivante, ainsi que d'un puissant processeur, en mesure de vous fournir différents fonctions, très utiles pour tous les secteurs alimentaires: la gestion du vide en pourcentage, la programmation du service, l'auto nettoyage de l'huile, le vide extérieur par «step», les 20 programmes memorisables, etc.. Enfin, sous votre requête, la machine sous vide sera équipée d'une imprimante pour étiquetter vos sachets, en améliorant la gestion et le stockage de vos produits.



Vasca doppia altezza  
Double height vacuum chamber

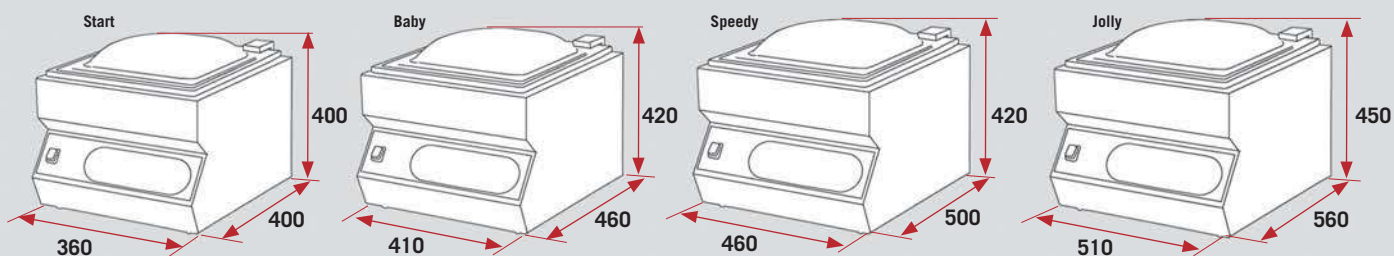

# START / BABY / SPEEDY / JOLLY / BOXER 45 BOXER DUO / BIG BOXER / BOXER 80



CONFE A CAMPANA DA BANCO  
table top vac packers



Hemos llegado al verdadero Top!!! Las envasadoras de la gama "Top Series" en la nueva variante representan una unión de calidad, design y rendimiento que las colocan seguramente en la cumbre de la categoría. Además de la nueva estructura muy resistente y verdaderamente cautivadora en la gama top hay un potente microprocesador que puede ofrecer muchas funciones muy útiles para todos los sectores de alimentación: desde la posibilidad de hacer el vacío con el sensor (con porcentaje) a la gestión ya programada del "call service" y a la función de autolimpieza bomba de vacío, desde la posibilidad de hacer el vacío con pausas del ciclo a los 20 programas que se pueden memorizar... Además, si quieren, podemos añadir a la máquina una pequeña impresora para etiquetar los envases, mejorando la gestión de los productos.

Diese Vakuuiergeräte stellen die „absolute Spitzen-Gruppe“ dar!!!! Die Verpackungsmaschinen der "Top-Serie" in ihrer neuen Version verstehen sich in Punkto Qualität, Design und Leistung als ideale Verschmelzung und stehen somit unbestritten an der Spitze der gesamten Kategorie. Jenseits der neuen extrem robusten Struktur und der ansprechenden Optik, wurde die gesamte Serie der Gruppe TOP mit leistungsfähigem Mikroprozessor ausgestattet. Aufgrund dieser Neuerung sind die Vakuuiergeräte in der Lage, eine Bandbreite an neuen nützlichen Funktionen im Bereich der Lebensmittelindustrie auszuüben: vom Selbstreinigungsmechanismus bis hin zur Speicherung von 20 Programmen, etc... Darüber hinaus kann auf Wunsch ein Mikro-Drucker für Ihre Etiketten angebracht werden, um somit eine verbesserte Handhabung und Kontrolle in der Lagerung Ihrer Produkte zu gewährleisten.



**BUSCH**  
Vacuum Pumps and Systems

visit our website  
Seguici su:  
[www.lavezzini.it](http://www.lavezzini.it)

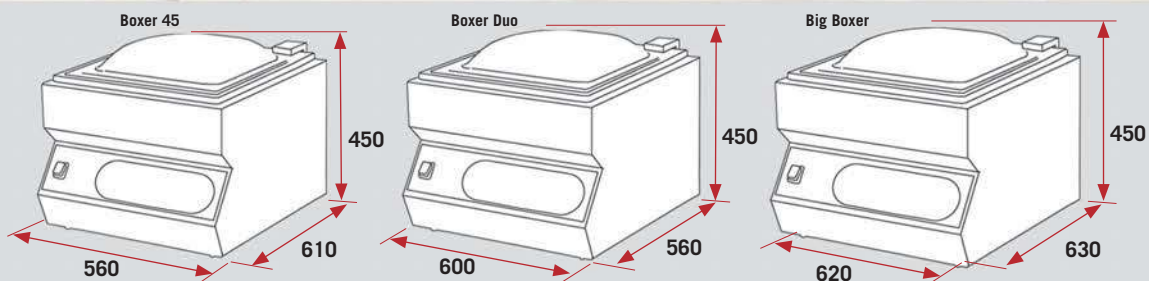

## PANNELLO COMANDI / control panel

Accensione/spengimento confezionatrice  
Attivazione funzione VAC STOP: interruzione anticipata del ciclo di vuoto  
*Packing machine's switch on/switch off Activation of VAC STOP FUNCTION (stop in advance the vacuum cycle) if you push the button twice*

Rientro dell'aria in camera soft e graduale  
*Gradual intake of air into the chamber*

+5 secondi di vuoto rispetto al programma impostato  
*5 seconds of vacuum more than the established program settings*

Regolazione livelli Vuoto / Gas / Saldatura  
*Level setting for Vacuum / Gas / Sealing*

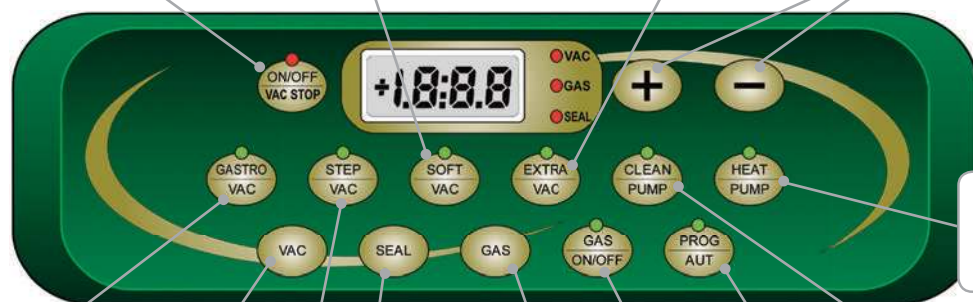

Funzione per vuoto in contenitori gastronorm  
*Vacuum system for gastro containers*

% di vuoto  
*Vacuum percentage*

Funzione per prodotti facilmente emulsionabili (es. Maionese)  
*Easily emulsifiable products' function (i.e. mayonnaise)*

Tempo di saldatura  
*Sealing time*

Tempo di immissione gas  
*Gas intake time*

Attivazione funzione ciclo gas  
*Activation function of the gas intake*

Sistema auto-pulizia olio pompa  
*Oil pump's auto-cleaning system*

Preriscaldamento pompa del vuoto  
*Vacuum pump's preheating*

Definizione programma da memorizzare  
*Vacuum programs' setting*

- 20 PRG
- SOFT VAC
- EXTRA VAC
- CLEAN PUMP
- STEP VAC
- SENSOR VAC

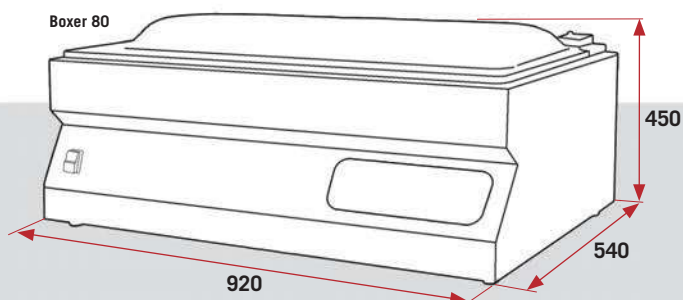

# START / BABY / SPEEDY / JOLLY / BOXER 45 BOXER DUO / BIG BOXER / BOXER 80



## STANDARD FUNCTIONS



**Pannello lcd multifunzione**  
(vedi pagina precedente)  
*Multifunction LCD panel*  
(see previous page)



**Soft air elettronico**  
*Electronic soft air*

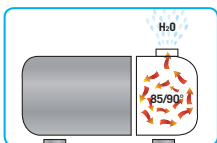

**Sistema autopulizia olio**  
*Oil made auto cleaning system*



**Vasca inox con angoli stondati senza saldature**  
*Entirely printed stainless steel vacuum chamber, with internal round corners*



**Barre saldanti estraibili**  
*Removable sealing bars*



**Connessione per attacco gastrovac**  
*Connection for the gastrovac system*



**Carter apribile a 90°**  
*90° openable carter*

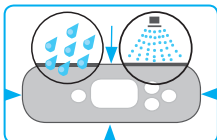

**Pannello comandi a totale tenuta contro umidità**  
*Waterproof control Panel*



**Set tavole di riempimento in polietilene**  
*Polyethylene filling squares set*

## OPTIONALS



**Predisposizione al gas inerte**  
*Arrangement for idle gas*



**Installazione stampante**  
*Printer installation*



**Vasca doppia altezza per confezionamento liquidi (JOLLY)**  
*Special double height vacuum chamber to pack liquids (JOLLY)*



**Pompa Busch**  
*Busch Pump*



**Sensore di vuoto**  
*Vacuum sensor*



**Barra saldante aggiuntiva**  
*Extra Sealing Bar*

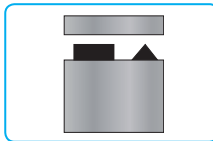

**Taglio Eccedenza**  
*Exceeding cutting bar*



**Sistema bloccaggio campana**  
*Lid Hook*



**Carrello supporto macchina**  
*Charriot on wheels*

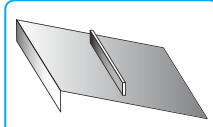

**Piano inclinato per liquidi**  
*Inclined plane for liquids*



**Tensione e frequenza speciale**  
*Voltage and speciale frequency*



# KRISTAL SERIES



330

**KRISTAL 330**
**KRISTAL 430**

430

Modello model modèles modelo Modelle	Struttura structure structure estructura Struktur	Dim. d'ingombro overall dimension dim. d'encombrement dimensiones Abmessungen	Dimensioni camera size of the chamber dim. de la càmbra Kammergröße	Barra saldante sealing bar barre de soudure barra soldante Schweißleiste	Pompa del vuoto vacuum pump pompe du vide bomba de vacío Vakuumpumpe	Peso weight poids peso Gewicht	Sistema di Saldatura Sealing System Système de Soudure Sistema de Soldadura Schweissystem	Assorbimento absorption absorption consumo Aufsaugen	Tensione voltage voltage tensión Spannung
KRISTAL 330inox		440x490x385 H	350x360x140 H	mm 330	Q= 8/9.6 m <sup>3</sup> h-0IL	KG 40	Con Pistoni/By Pistons	W 450	230 V/50-60 Hz
KRISTAL 430inox		550x580x425 H	450x460x140 H	mm 430	Q= 12/14.4 m <sup>3</sup> h-0IL	KG 52	Con Pistoni/By Pistons	W 650	230 V/50-60 Hz

## KRISTAL 330 / KRISTAL 430



Si tratta di confezionatrici sottovuoto dal design innovativo, particolarmente indicate per il settore della Grande Distribuzione. L'estrema facilità di pulizia del piano di lavoro dovuta alla totale removibilità delle barre saldanti oltre ad un pannello comandi dotato di 20 prg memorizzabili, conferiscono a questa linea di confezionatrici un valore aggiunto immediatamente percepibile da qualsiasi operatore.



CONF. A CAMPANA DA BANCO  
table top vac packers



*These vacuum packing machines, with their innovative design, are strongly recommended for the large-scale retail trade.*

*Its easily cleanable work surface – thanks to its totally removable sealing bars – as well as its control panel equipped with 20 storable work programs give these models an undisputed further value.*



*Il s'agit de machines sous vide avec un design novateur, très indiquées pour le secteur de la Grande Distribution.*

*L'extrême facilité de nettoyage de la surface de travail, due à la totale amovibilité des barres de soudure, ainsi que un panneau des commandes équipé de 20 programmes réglables, donnent à cette ligne de machines un surplus de qualité que l'utilisateur reconnaît tout de suite.*



*Son envasadoras al vacío con un design innovador, indicadas para los supermercados.*

*La limpieza del plano de trabajo que es muy fácil gracias a la posibilidad de quitar del todo las barras soldantes y el panel de mandos que tiene 20 programas hacen que esta gama tenga un valor añadido que cada usuario entiende en seguida.*



Es handelt sich um innovative Vakuumgeräte, die besonders geeignet für die Einzelhandelsketten sind.

Die Maschinen sind mit einer 20-Programme-Platine ausgerüstet und ihre Arbeitsplatte ist sehr einfach zu reinigen, da die Schweissbalken sind völlig abnehmbar.

Diese Eigenschaften machen die Maschinen noch interessanter für die Anwender, die einfach ihre Arbeitsbedeutung verstehen können.

KRISTAL 330

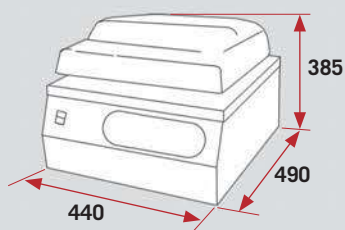

KRISTAL 430

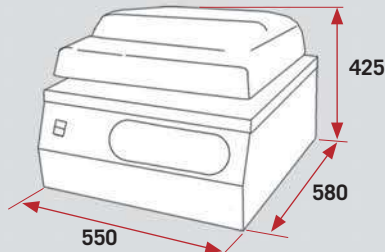

INOX CE



---

**CONFEZIONATRICI  
A CAMPANA SU RUOTE**

**FLOOR STANDING VAC  
PACKERS**

**MACHINES SOUS VIDE  
À CLOCHE SUR ROULETTES**

**ENVASADORAS A CAMPANA  
CON RUEDAS**

**EINKAMMER-STANDMASCHINEN**

LAPACK Series PAG 40



BOXER L LCD - 450 LCD - 450 S LCD



500 LCD - 550 S LCD - 900 S LCD



1000 SL LCD - 550 S DUPLEX LCD -  
500 VARIANT LCD

LEGENDA SIMBOLI:



Costruito nel rispetto dell'ambiente  
Environment friendly manufactured  
Construit en respectant l'environnement  
Fabricado respetando el ambiente  
Umweltfreundliche Herstellung



Ideale per salumifici e settore caseario  
Suitable for Ham factories, dairy farming  
Idéal pour la production de charcuterie et fromagerie  
Ideal par charcuterías pequeños fábricas de quesos  
Ideal für Wurstwarenfabriken und Käseindustrie.



Ideale per alimentari e gastronomie  
Suitable for food shops and delicatessen  
Idéal pour alimentaires et gastronomies  
Ideal para detallantes y gastronomías  
Ideal für Lebensmittelverarbeitende Betriebe und Gastronomie



Ideale per supermercati e macellerie  
Suitable for supermarkets and butcheries  
Idéal pour supermarchés et boucheries  
Ideal para supermercados y carnicerías  
Ideal für Supermärkte und Metzgereien



Ideale per ristoranti  
Suitable for restaurants  
Idéels pour restaurants  
Ideal para restaurantes  
Ideal für Restaurants



BOXER L

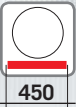

450



450 S



Modello model modèles modelo Modelle	Struttura structure modèles estructura Struktur	Dim. d'ingombro overall dimension dim. d'encombrement dimensiones Abmessungen	Dimensioni camera size of the chamber dim. de la chambre dim. de la càmara Kammergröße	Barra saldante sealing bar barre de soudure barra soldante Schweißleiste	Pompa del vuoto vacuum pump pompe du vide bomba de vacío Vakuumpumpe	Peso weight poids peso Gewicht	Assorbimento absorption absorption consumo Aufsaugen	Tensione voltage voltage tensión Spannung
BOXER L	inox	560X610X1050 H	460X500X220 H	mm 450	Q= 25/30 m <sup>3</sup> h-0IL	KG 90	W 900	230 V/50-60 Hz
450	inox	580X660X1050 H	460X560X220 H	mm 450	Q= 25/30 m <sup>3</sup> h-0IL	KG 110	W 900	230 V/50-60 Hz
450 S	inox	680X570X1050 H	560X460X220 H	2x (mm 450)	Q= 25/30 m <sup>3</sup> h-0IL	KG 110	W 1000	230 V/50-60 Hz

## BOXER L / 450 / 450 S



Confezionatrici professionali a campana di elevata qualità ed estrema cura dei dettagli strutturali.

Le versioni sottoriportate applicabili ai più svariati settori d'utilizzo, trovano applicazioni nella media-azienda in genere.

Le ottime prestazioni e l'elevata resa produttiva vengono integrate da un innovativo pannello comandi digitale LCD multifunzione che ne esalta le caratteristiche.



Professional packaging machines with bell characterised by an elevated quality and high care of structural details. The versions herewith are suitable for different sectors and they find applications in the general middle enterprises. The perfect performances and the elevated productive output are integrated with an innovative multifunctional digital control panel LCD that exalts the features.



Machines de conditionnement professionnelles à cloche d'élevée qualité et d'extrême soin des détails structurels. On peut appliquer les versions ci-dessous aux plus divers secteurs d'utilisation et en général dans les entreprises. Un innovateur panneau à commandes digitaux LCD multifonctionnel intègre les très bonnes prestations et l'élevée productivité de la machine en exaltant ses caractères.



Diese professionelle Maschine zur Vakuumverpackung mit Glocke haben eine hohe Qualität und Sorgfalt fuer die strukturellen Details. Die verschiedene Ausfuehrungen, geeignet fuer zahlreiche Sektoren, finden verschiedene Anwendungen in der mittel Firma. Die hervorragende, produktive Leistungen werden mit einer innovativen, mehrfunktionalen und digitalen Steuertafel LCD integriert, ihre Merkmale unterstreicht.



Envasadoras al vacío profesionales a campana de elevada calidad y extrema atención para los detalles estructurales. Los modelos indicadas abajo, que se pueden utilizar en diferentes sectores, son utilizados en la media empresa. Las óptimas prestaciones y el elevado rendimiento productivo se unen a una innovativa placa con mandos digital LCD multifuncional que exalta las características de este modelo.



Nuova guarnizione in silicone a ventosa  
New silicone sucker gasket

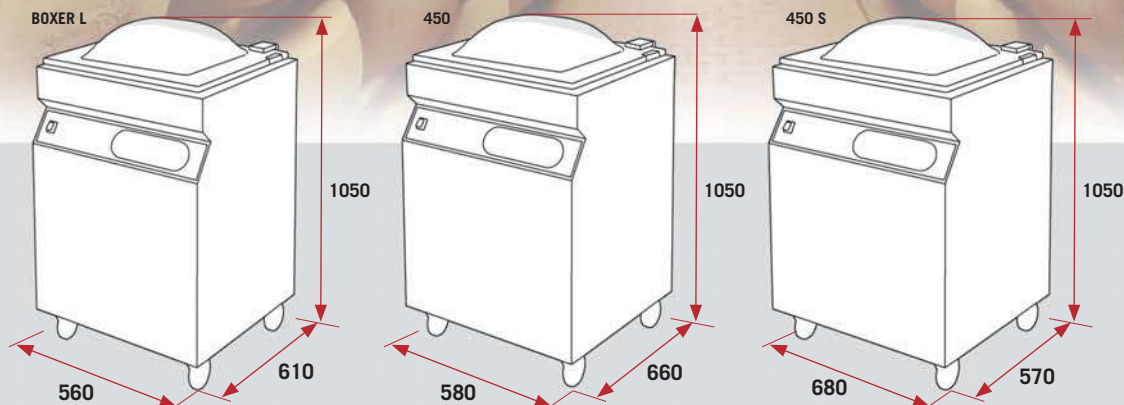

## PANNELLO COMANDI / control panel

Accensione/spengimento confezionatrice  
Attivazione funzione VAC STOP: interruzione anticipata del ciclo di vuoto  
*Packing machine's switch on/switch off Activation of VAC STOP FUNCTION (stop in advance the vacuum cycle) if you push the button twice*

Rientro dell'aria in camera soft e graduale  
*Gradual intake of air into the chamber*

+5 secondi di vuoto rispetto al programma impostato  
*5 seconds of vacuum more than the established program settings*

Regolazione livelli Vuoto / Gas / Saldatura  
*Level setting for Vacuum / Gas / Sealing*

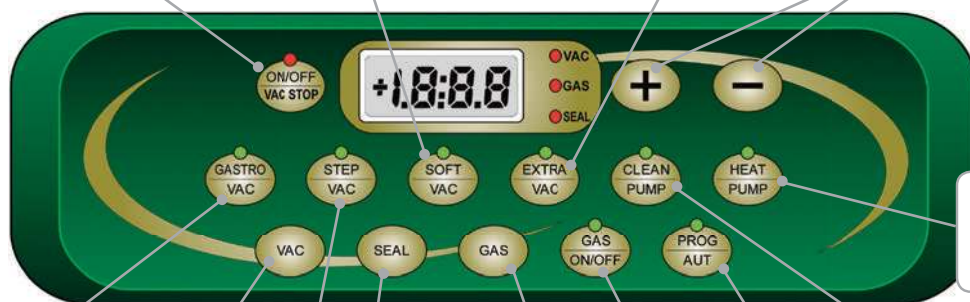

Funzione per vuoto in contenitori gastronorm  
*Vacuum system for gastro containers*

% di vuoto  
*Vacuum percentage*

Tempo di immissione gas  
*Gas intake time*

Tempo di saldatura  
*Sealing time*

Funzione per prodotti facilmente emulsionabili (es. Maionese)  
*Easily emulsifiable products' function (i.e. mayonnaise)*

Attivazione funzione ciclo gas  
*Activation function of the gas intake*

Definizione programma da memorizzare  
*Vacuum programs' setting*

Preriscaldamento pompa del vuoto  
*Vacuum pump's preheating*

Sistema auto-pulizia olio pompa  
*Oil pump's auto-cleaning system*

## DISPOSIZIONE BARRE SALDANTI / Sealing bars position

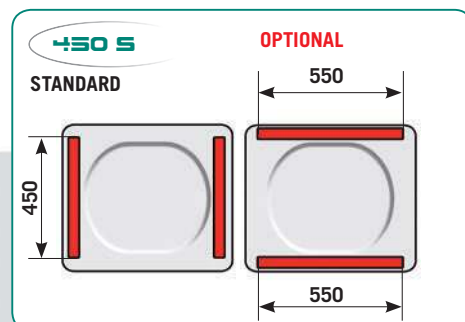
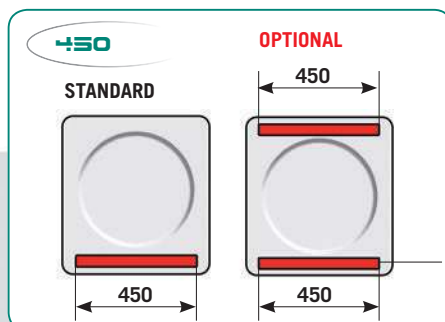
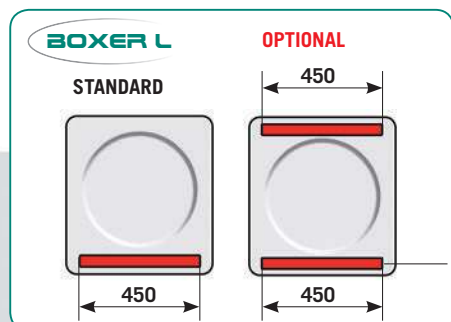

## BOXER L / 450 / 450 S

## STANDARD FUNCTIONS



**Pannello lcd multifunzione**  
(vedi pagina 5)  
*Multifunction LCD panel*  
(see page 5)



**Soft air elettronico**  
*Electronic soft air*

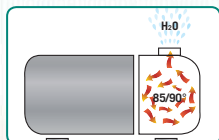

**Sistema autopulizia olio**  
*Oil made auto cleaning system*



**Vasca inox con angoli stondati senza saldature**  
*Entirely printed stainless steel vacuum chamber, with internal round corners*



**Barre saldanti estraibili**  
*Removable sealing bars*

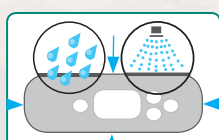

**Pannello comandi a totale tenuta contro umidità**  
*Waterproof control Panel*



**Set tavole di riempimento in polietilene**  
*Polyethylene filling squares set*

## OPTIONALS



**Predisposizione al gas inerte**  
*Arrangement for idle gas*



**Installazione stampante**  
*Printer installation*



**Pompa Busch**  
*Busch Pump*



**Sensore di vuoto**  
*Vacuum sensor*



**Barra saldante aggiuntiva**  
*Extra Sealing Bar*

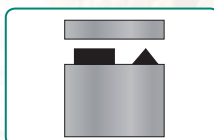

**Taglio Eccedenza**  
*Exceeding cutting bar*



**Sistema bloccaggio campana**  
*Lid Hook*

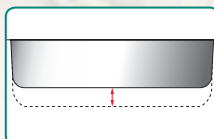

**Altezza camera maggiorata**  
*Increased chamber height*

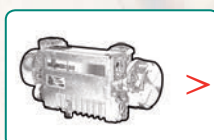

**Pompa vuoto maggiorata**  
*Increased vacuum pump*



**Tensione e frequenza speciale**  
*Voltage and speciale frequency*



500



500



550 S

550



900 S

500

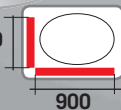

900

Modello model modèles modelo Modelle	Struttura structure structure estructura Struktur	Dim. d'ingombro overall dimension dim. d'encombrement dimensiones Abmessungen	Dimensioni camera size of the chamber dim. de la chambre dim. de la cámara Kammergröße	Barra saldante sealing bar barre de soudure barra soldante Schweißleiste	Pompa del vuoto vacuum pump pompe du vide bomba de vacío Vakuumpumpe	Peso weight poids peso Gewicht	Assorbimento absorption absorption consumo Aufsaugen	Tensione voltage voltage tensión Spannung
500	inox	630x760x1050 H	510x650x220 H	mm 500	Q= 60/72 m <sup>3</sup> h-OIL	Kg 140	W 1300	380 V/50-60 Hz
550 S	inox	840x680x1050 H	720x570x220 H	2x (mm 550)	Q= 60/72 m <sup>3</sup> h-OIL	Kg 160	W 1450	380 V/50-60 Hz
900 S	inox	1040x680x1050 H	920x570x220 H	mm 900/mm 500	Q= 100/120 m <sup>3</sup> h-OIL	kg 200	W 2400	380 V/50-60 Hz

## 500 / 550 S / 900 S



Confezionatrici professionali a campana di estrema qualità concepite per applicazioni di tipo industriale. Elettronica e meccanica d'elevata affidabilità e continuità operativa.

Le pompe per vuoto installate offrono estrema silenziosità e prestazioni veramente sorprendenti.



Professional packaging machines with bell characterised by high quality for industrial applications. Electric and mechanical with an high reliability and operative continuity. The installed vacuum pumps, extremely silent, offer really amazing performances.



Machines de conditionnement professionnelles à cloche d'extrême qualité, conçues pour applications de genre industriel. Electronique et mécanique d'élevée fiabilité et continuité opérationnelle. Les pompes du vide installées, énormément silencieuses, offrent performances vraiment surprenantes.



Envasadoras profesionales a campana de alta calidad concebidas para aplicaciones de tipo industrial. Electrónica, elevada fiabilidad y continuidad operativa son las características que exaltan ese modelo. Las bombas de vacío puestas en las maquinas son muy silenciosas y garantizan un rendimiento optimo.



Diese professionelle Maschine zur Vakuumverpackung mit Glocke und hoch Qualitaet werden fuer industrielle Anwendungen ausgedacht. Diese elektronische Maschine hat eine besondere Zuverlaessigkeit und operative Kontinuitaet. Die installierte Vakuumpumpe bieten eine hoehere Stille und hoechste Garantie der operativen Kontinuitaet.

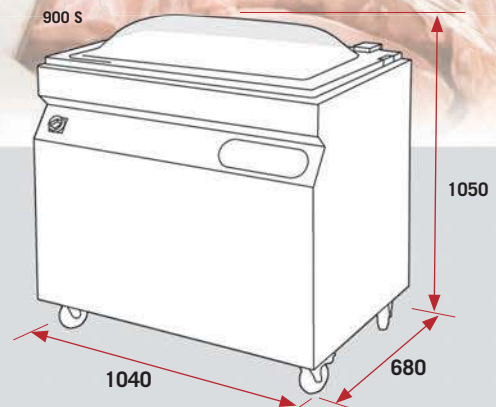
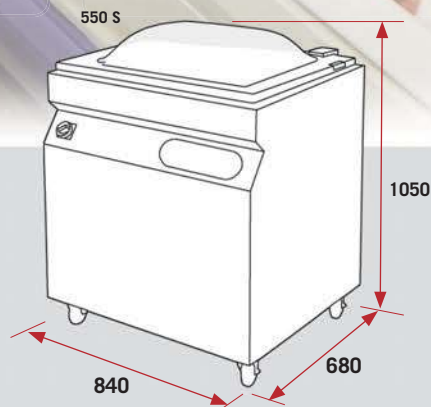
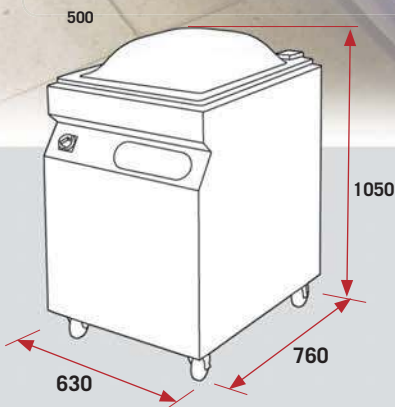

## DISPOSIZIONE BARRE SALDANTI / Sealing bars position

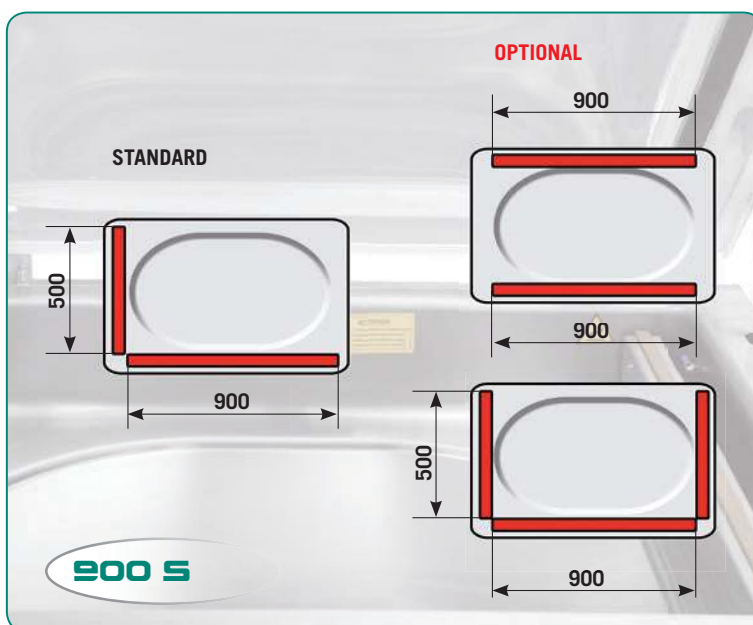
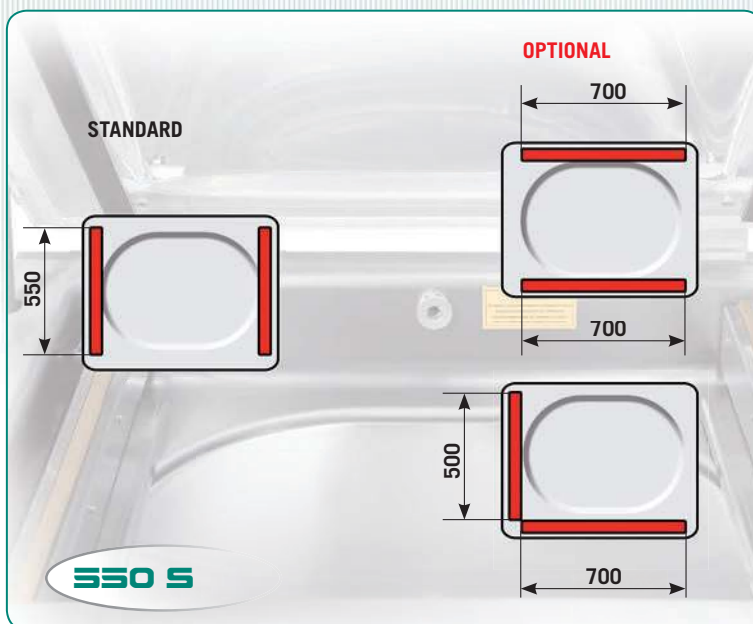
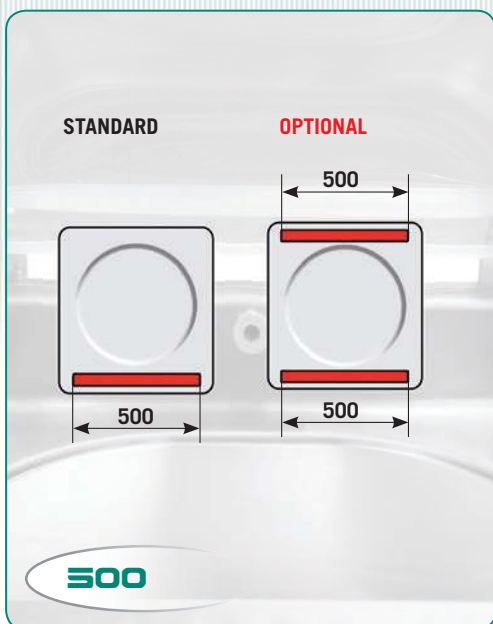

## STANDARD FUNCTIONS



**Pannello lcd multifunzione**  
(vedi pagina 5)  
*Multifunction LCD panel*  
(see page 5)



**Soft air elettronico**  
*Electronic soft air*

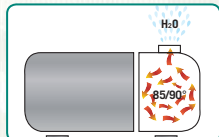

**Sistema autopulizia olio**  
*Oil made auto cleaning system*



**Vasca inox con angoli stondati senza saldature**  
*Entirely printed stainless steel vacuum chamber, with internal round corners*



**Barre saldanti estraibili**  
*Removable sealing bars*

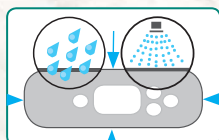

**Pannello comandi a totale tenuta contro umidità**  
*Waterproof control Panel*

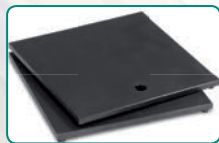

**Set tavole di riempimento in polietilene**  
*Polyethylene filling squares set*

## OPTIONALS



**Predisposizione al gas inerte**  
*Arrangement for idle gas*



**Installazione stampante**  
*Printer installation*



**Pompa Busch**  
*Busch Pump*



**Sensore di vuoto**  
*Vacuum sensor*



**Barra saldante aggiuntiva**  
*Extra Sealing Bar*

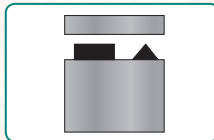

**Taglio Eccedenza**  
*Exceeding cutting bar*



**Sistema bloccaggio campana**  
*Lid Hook*

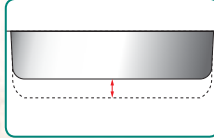

**Altezza camera maggiorata**  
*Increased chamber height*



**Pompa vuoto maggiorata**  
*Increased vacuum pump*



**Tensione e frequenza speciale**  
*Voltage and speciale frequency*



1000 SL

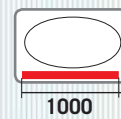

DUPLEX



Modello model modèles modelo Modelle	Struttura structure structure estructura Struktur	Dim. d'ingombro overall dimension dim. d'encombrement dimensiones Abmessungen	Dimensioni camera size of the chamber dim. de la chambre dim. de la càmara Kammergröße	Barra saldante sealing bar barre de soudure barra soldante Schweißleiste	Pompa del vuoto vacuum pump pompe du vide bomba de vacío Vakuumpumpe	Peso weight poids peso Gewicht	Assorbimento absorption absorption consumo Aufsaugen	Tensione voltage voltage tensión Spannung
1000 SL	inox	1140x590x1050	1020x420x200	mm 1000	Q= 60/72 m <sup>3</sup> h-0IL	kg 160	W 1450	380 V/50-60 Hz
550 S DUPLEX	inox	1680x680x1050	(720x570x220)x 2	(2xmm550) x2	Q= 100/120 m <sup>3</sup> h-0IL	kg 260	W 2600	380 V/50-60 Hz

# 1000 SL / 550 S DUPLEX



Confezionatrici professionali per industria di elevata qualità concepite per lavoro a ciclo continuo. Applicazione ideale in salumifici, settore caseario, centri distribuzione alimentari ecc. Scheda elettronica schermata e protetta da interferenze esterne-sistema saldante a banda larga 5 mm ideale per qualsiasi tipologia di sacchetto utilizzato.



Professional packaging machines for industry with a high quality and conceived for a working continuing cycle. Application for salami and cheese factories and food distribution centres.

The electronic card is protected from external interferences. The sealing system is equipped with a band of 5 mm., suitable for any kind of used bags.



Stampante per etichette  
Printer for bags labels



Machines de conditionnement professionnelles à cloche d'extrême qualité, conçues pour applications de genre industriel.

Electronique et mécanique d'élevée fiabilité et continuité opérationnelle.

Platine électronique masquée et protégée des interférences extérieures. Système de soudure avec bande de 5 mm, à utiliser avec sachets de différentes typologies.



Envasadoras al vacío profesionales para industria. Son de elevada calidad y permiten un funcionamiento a ciclo continuo. Esa máquina es la más apta para tocinerías, queserías, lugares de distribución alimenticia...

La ficha electrónica protegida por interferencias externas y el sistema soldante con una barra de 5 mm, ideal para cualquier tipo de bolsas utilizadas, son la características más interesantes de ese modelo.

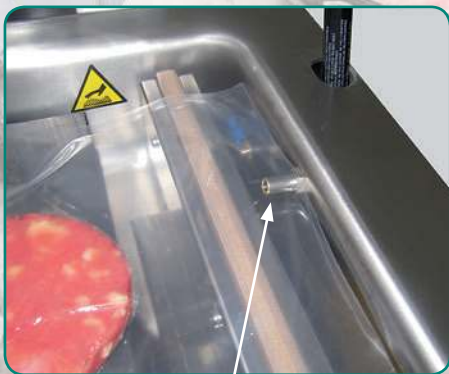

Ugello iniezione gas inerte  
Inert gas injection nozzle



Diese professionelle Maschine zur Vakuumpackung fuer die Industrie werden mit einer hoch Qualitaet ausgedacht, besonders fuer die Arbeit mit dauerndem Zyklus. Ihre Anwendung ist fuer die Wurstfabrik geeignet, die Kaese- und Lebensmittelindustrie und so weiter. Die elektronische Karte wird von ausseren Stoergeraueschen geschuetzt. Die Schweissensystem mit breitem Band von 5 mm ist fuer irgendetwelchen Beutel geeignet.

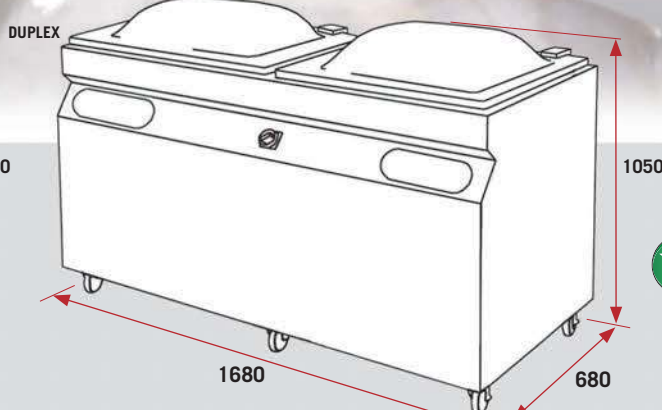
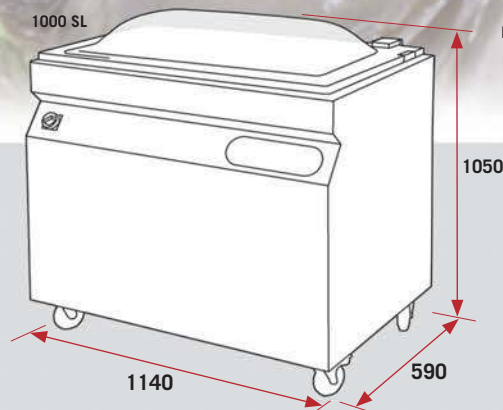

INOX CE



# LAPACK SERIES

## 1000 SL / 550 S DUPLEX

### STANDARD FUNCTIONS



**Pannello lcd multifunzione**  
(vedi pagina 5)  
*Multifunction LCD panel*  
(see page 5)



**Soft air elettronico**  
*Electronic soft air*

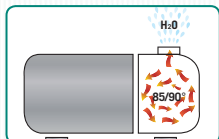

**Sistema autopulizia olio**  
*Oil made auto cleaning system*



**Vasca inox con angoli stondati senza saldature**  
*Entirely printed stainless steel vacuum chamber, with internal round corners*



**Barre saldanti estraibili**  
*Removable sealing bars*

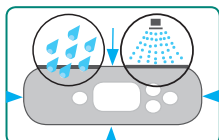

**Pannello comandi a totale tenuta contro umidità**  
*Waterproof control Panel*

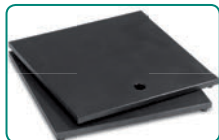

**Set tavole di riempimento in polietilene**  
*Polyethylene filling squares set*

### OPTIONALS



**Predisposizione al gas inerte**  
*Arrangement for idle gas*



**Installazione stampante**  
*Printer installation*



**Pompa Busch**  
*Busch Pump*



**Sensore di vuoto**  
*Vacuum sensor*



**Barra saldante aggiuntiva**  
*Extra Sealing Bar*

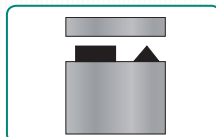

**Taglio Eccedenza**  
*Exceeding cutting bar*



**Sistema bloccaggio campana**  
*Lid Hook*

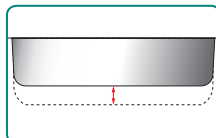

**Altezza camera maggiorata**  
*Increased chamber height*



**Pompa vuoto maggiorata**  
*Increased vacuum pump*



**Tensione e frequenza speciale**  
*Voltage and speciale frequency*

### DISPOSIZIONE BARRE SALDANTI / Sealing bars position

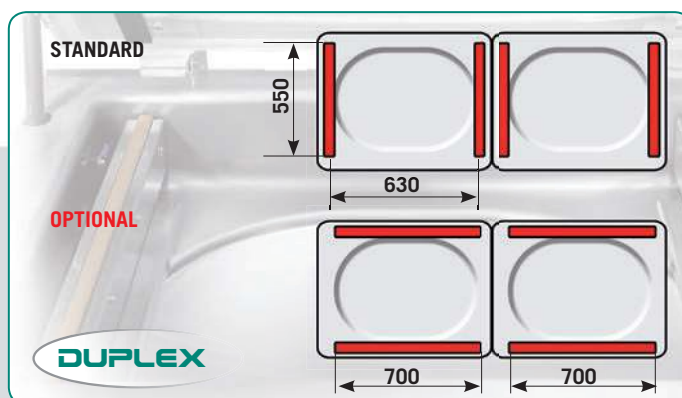
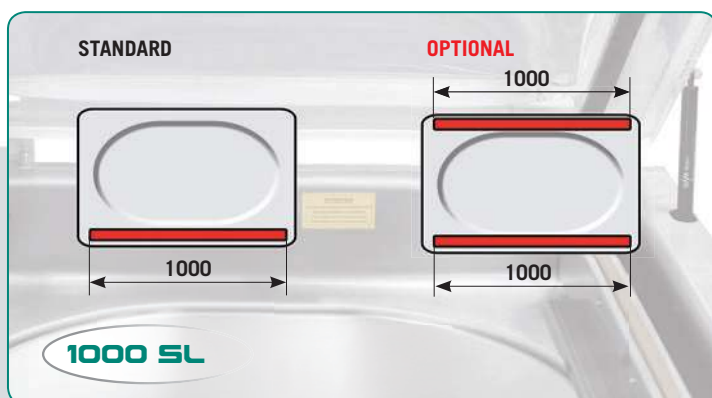

## 500 VARIANT



Confezionatrice sottovuoto professionale verticale ideale per laboratorio e media-azienda. Con appositi stampi verticali interni (a misura) realizza confezioni perfettamente squadrate di prodotti in polvere, macinati e in grani (es. riso, caffè, ecc)

Inoltre operando in verticale si rende ottimale per il confezionamento sottovuoto di liquidi, salse e sughi.....etc.



Vacuum packaging machine on wheels with "vertical chamber", especially conceived for workrooms and medium sized businesses. Thanks to specific internal vertical moulds (To be made under request) it creates perfectly squared packets for any powder or granular products (E.g. Rice, coffee beans...)

Moreover, the "vertical work" is particularly suitable to pack liquids, sauces etc...



Machine sous vide professionnelle, verticale, pensée pour laboratoires et moyenne entreprise. Avec moules intérieurs spéciaux (sur mesure), il est possible de réaliser boîtes carrées de produits en poudre, moudés ou bien en grains (ex. riz, café, etc..).

De plus, en travaillant verticalement, elle est très conseillée pour conditionner liquides, sauces, etc.. »



Envasadora al vacío profesional con cuba vertical, perfecta para los obradores y para las empresas medianas. Tiene moldes particulares, internos y verticales ( hechos a medida ) que le permiten hacer paquetes perfectamente cuadrados de productos en polvo, molinos y en granos (ej. Arroz, café...)

Además al tener la cuba vertical es perfecta para envasar al vacío líquidos, mayonesas y diferentes salsas...



Diese professionelle vertikale Maschine zur Vakuum Verpackung ist ideal fuer mittel Firmen und Werkstaetten. Mit dafuer vorgesehenen vertikalen internen Formen (zur Mass) produziert sie perfekt rechteckige Verpackungen fuer Pulverprodukte, sowohl gemahlt als auch in Koerne (zum Beispiel Reis, Kaffee,...). Ausserdem, da sie vertical arbeitet, ist sie hervorragend fuer die Verpackung von Flussigkeiten, Soessen, usw.



VARIANT

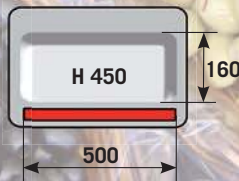

Modello model modèles modelo Modelle	Dim. d'ingombro overall dimension dim. d'encombrement dimensiones Abmessungen	Dimensioni camera size of the chamber dim. de la chambre dim. de la càmara Kammergröße	Barra saldante sealing bar barre de soudure barra soldante Schweißleiste	Pompa del vuoto vacuum pump pompe du vide bomba de vacío Vakuumpumpe	Peso weight poids peso Gewicht	Assorbimento absorption absorption consumo Aufsaugen	Tensione voltage voltage tensión Spannung
--	---	--	--	--	--	--	---

500 VARIANT 670x410x1000 510x160x450 H mm 500 Q= 25/30 m<sup>3</sup>h-OIL kg 130 W 900 230 V/50-60 Hz



---

**CONFEZIONATRICI  
A CAMPANA PER L'INDUSTRIA**

**INDUSTRIAL VAC PACKERS**

**MACHINES SOUS VIDE  
À CLOCHE POUR L'INDUSTRIE**

**ENVASADORAS A CAMPANA  
PARA LA INDUSTRIA**

**KAMMERGERÄTE FÜR  
INDUSTRIEBRANCHE**



L'impresa Lavezzini è lieta di presentare la nuova Linea di Confezionatrici per l'industria: SUPER-TECH LINE.

Si tratta di una linea di macchine sottovuoto studiate e progettate per un target di clientela per il quale la confezionatrice rappresenta uno strumento indispensabile di lavoro inserito in più ampio ciclo produttivo.



*It's a brand new line of vacuum packing machines specific for the industry. This range was conceived to be a fundamental phase of a more complete working cycle. SUPER-TECH line fully meets these three fundamental principles:*

- High quality of every manufacturing material
- Extremely high productive standards
- Technological excellence

*High quality in its every single part Every single component of these machines was carefully and strictly tested by our technical team to be fully suitable: this is a necessary condition for a line of machines conceived to stand an intensive and permanent work.*

*Extremely high productive standards The long planning and testing led to the creation of a range of machines which have to be an irreplaceable instrument for your activity and, consequently, ready to stand high production rates.*

*Technological excellence This line of vacuum packers can offer undoubted technological excellencies, both from an electronic side (Its multi-functional and multi-program LCD control panel) and from a structural point of view (Its 6 mm thick inox cover, its extremely firm work surface and the external carter).*

*SUPER-TECH line meets the specific packing requirements for:*

La nuova LINEA SUPER-TECH infatti è stata concepita nel pieno rispetto di tre principi cardine:

- Ottima qualità dei materiali utilizzati
- Elevati standard produttivi
- Eccellenza tecnologica

#### OTTIMA QUALITA' DEI MATERIALI UTILIZZATI

Questa peculiarità rappresenta il necessario presupposto per confezionatrici sottovuoto concepite per un'attività intensa e continuativa. Tutti i materiali impiegati infatti, sono stati testati e collaudati dal nostro team tecnico che ne ha valutato l'idoneità solo a seguito del superamento di rigidi test di collaudo.

#### ELEVATI STANDARD PRODUTTIVI

Le intense e prolungate attività di progettazione e di realizzazione hanno permesso la realizzazione di confezionatrici ideate per ambienti lavorativi in cui la confezionatrice sottovuoto è concepita come strumento indispensabile di lavoro, soggetta quindi a ritmi di lavoro elevati e persistenti.

#### ECCELLENZA TECNOLOGICA

La linea SUPER-TECH presenta caratteri di eccellenza tecnologica sia dal punto di vista elettronico (pannello comandi LCD polifunzionale e multi-programmabile) sia dal punto di vista strutturale (campana inox, spessore 6 mm, piano e struttura inox di solida consistenza).

La LINEA SUPER-TECH, rispondendo a rigidi canoni di produzione, è rivolta a soddisfare le esigenze di confezionamento di determinati target di clientela:

- Caseifici
- Salumifici
- Centri di confezionamento
- Laboratori di macellazione
- Cheese factories
- Salami factories
- Packing centres
- Slaughter labs

### SUPER-TECH Series PAG 54

TOP



ULTRA  
MEGA  
JUMBO



JUMBO SUPER  
SUPERMEGA



#### LEGENDA SIMBOLI:



Costruito nel rispetto dell'ambiente  
Environment friendly manufactured  
Construit en respectant l'environnement  
Fabricado respetando el ambiente  
Umweltfreundliche Herstellung



Ideale per salumifici e settore caseario  
Suitable for Ham factories, dairy farming  
Idéal pour la production de charcuterie et fromagerie  
Idéal par charcuteries pequeños fábricas de quesos  
Ideal für Wurstwarenfabriken und Käseindustrie.



Ideale per alimentari e gastronomie  
Suitable for food shops and delicatessen  
Idéal pour alimentaires et gastronomies  
Idéal para detallantes y gastronomías  
Ideal für Lebensmittelverarbeitende Betriebe und Gastronomie



Ideale per supermercati e macellerie  
Suitable for supermarkets and butcheries  
Idéal pour supermarchés et boucheries  
Idéal para supermercados y carnicerías  
Ideal für Supermärkte und Metzgereien



Ideale per ristoranti  
Suitable for restaurants  
Idéels pour restaurants  
Idéal para restaurantes  
Ideal für Restaurants

# SUPER-TECH SERIES

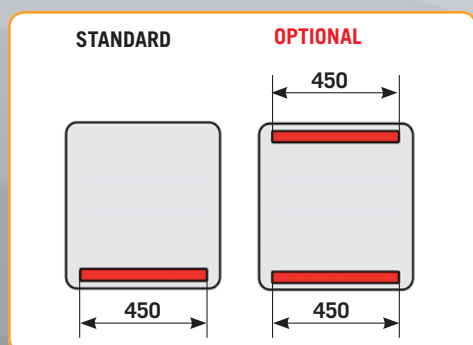

DISPOSIZIONE BARRE SALDANTI / Sealing bars position

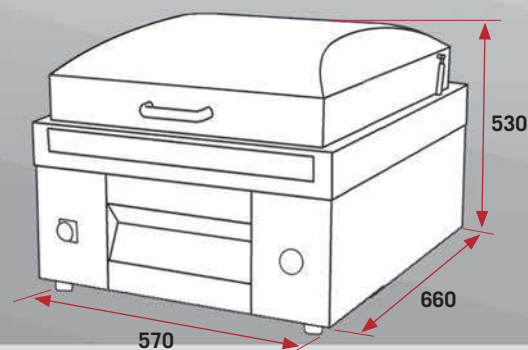

Modello model modèles modelo Modelle	Struttura structure structure estructura Struktur	Dim. d'ingombro overall dimension dim. d'encombrement dimensiones Abmessungen	Dimensioni camera size of the chamber dim. de la chambre dim. de la càmara Kammergröße	Barra saldante sealing bar barre de soudure barra soldante Schweißleiste	Pompa del vuoto vacuum pump pompe du vide bomba de vacío Vakuumpumpe	Peso weight poids peso Gewicht	Assorbimento absorption absorption consumo Aufsaugen	Tensione voltage voltage tensión Spannung
TOP	inox	570x660x530h	470x530x220h	mm 450	Q= 20/24 m <sup>3</sup> h-OIL	KG 90	W 900	230 V/50-60 Hz

## TOP



Rappresenta una soluzione eccellente per quella fascia di clientela esigente in termini di qualità del prodotto, robustezza ed affidabilità dell'apparecchiatura alla quale poter chiedere in qualsiasi momento anche il più gravoso carico produttivo con la garanzia di un risultato certo.



It's the Excellency solution for those extremely demanding customers about product quality, compactness and reliability of the equipment to have in any moment a guaranteed final result even for the hardest working cycle



Ce modèle represent une excellente solution pour toute la clientèle exigeante qui recherche un produit robuste, fiable et de qualité, un appareil auquel pouvoir demander un charge de production lourde, avec certitude de bons résultats.



Este modelo es la solución ideal para aquellos clientes exigentes por lo que concierne la calidad del producto, solidez y fiabilidad de la maquina. La TOP puede soportar la más gravosa carga de producción con la garantía de un resultado cierto.



Diese Linie ist die ausgezeichnete Lösung für diesen anspruchsvollen Kunden die, hohe Produktqualität, Robustheit und Apparatsicherheit suchen und Sie können im jeden Moment eine hohe Produktivverladung mit einem sicheren Resultat bekommen.

## STANDARD FUNCTIONS



**Pannello lcd multifunzione**  
(vedi pagina 13)  
*Multifunction LCD panel*  
(see page 13)



**Soft air elettronico**  
*Electronic soft air*

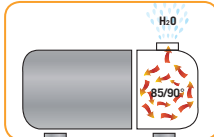

**Sistema autopulizia olio**  
*Oil made auto cleaning system*

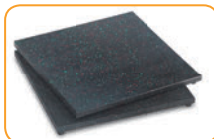

**Set tavole di riempimento in polietilene**  
*Polyethilene filling squares set*

## OPTIONALS



**Predisposizione al gas inerte**  
*Arrangement for idle gas*



**Installazione stampante**  
*Printer installation*



**Pompa Busch**  
*Busch Pump*



**Sensore di vuoto**  
*Vacuum sensor*



**Differente disposizione barre saldanti**  
*Different position of the sealing bars*

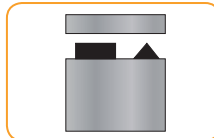

**Taglio Eccedenza**  
*Exceeding cutting bar*

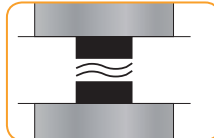

**Barra contrapposta biattiva**  
*Opposed sealing bar (beactive)*



**Tensione e frequenza speciale**  
*Voltage and speciale frequency*

# SUPER-TECH<sup>®</sup> SERIES



## ULTRA



Rappresenta la soluzione ottimale per l'industria di medio grandi dimensioni che necessita di macchine a ciclo operativo continuativo o intermittente a seconda delle specifiche esigenze.

La flessibilità dell'apparecchiatura, la disposizione a scelta delle barre saldanti e la solidità strutturale di cui dispongono tutti i modelli collocano le confezionatrici mono-campana SUPER-TECH nei settori industriali più disparati con eccellenti risultati nei vari processi produttivi.



ULTRA

### DISPOSIZIONE BARRE SALDANTI / Sealing bars position

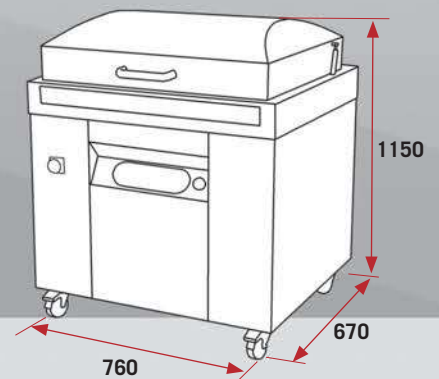
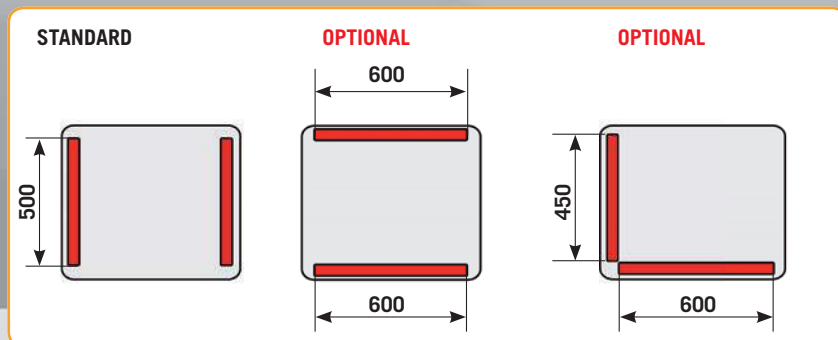

Modello model modèles modelo Modelle	Struttura structure structure estructura Struktur	Dim. d'ingombro overall dimension dim. d'encombrement dimensiones Abmessungen	Dimensioni camera size of the chamber dim. de la chambre dim. de la cámara Kammergröße	Barra saldante sealing bar barre de soudure barra soldante Schweißleiste	Pompa del vuoto vacuum pump pompe du vide bomba de vacío Vakuumpumpe	Peso weight poids peso Gewicht	Assorbimento absorption absorption consumo Aufsaugen	Tensione voltage voltage tensión Spannung
ULTRA	inox	760x670x1150h	660x530x230h	2x(mm 500)	Q= 60/72 m <sup>3</sup> /h-OIL	KG 160	W 1300	380 V/50-60 Hz



INOX | CE



It's the optimum solution for the medium/large sized industry requiring for a vacuum packing machines with permanent of irregular working cycle, depending on its needs. The equipment flexibility, the placing of the sealing bars on request and the compactness granted for each model make this range of "SUPER-TECH" machines suitable to the most varied application fields with the best results.



Ces modèles représentent une très bonne solution pour l'industrie de moyennes/grandes dimensions, qui a nécessité d'un cycle opérationnel continu ou intermittent, selon les différentes exigences. La flexibilité des appareils, la disposition à votre choix des barres de soudure, et la solidité structurelle dont ils sont équipés, lui permettent de ce placer dans les plus différents secteurs d'usage, avec excellents résultats.



Estas máquinas son ideales para la industria medio – grande que necesita máquinas que trabajen de continuo o con pausas, según las exigencias. La flexibilidad del aparato, la posibilidad de elegir la posición de las barras soldantes y la solidez de la estructura hacen que todas las envasadoras mono-campana SUPER-TECH sean ideales para todos los diferentes sectores de la industria y que logren excelentes resultados en todos los procesos de producción.



Das ist die Lösung für die Medium / Grosse Firma, die dauerhaften Produktionsablauf braucht. Durch die Flexibilität der Apparatur, die Anordnung der Schweissleisten und die wichtige Struktur stellt diese „SUPERTECH“ Maschine mit dem bestem Resultaten in allen industriellen Sektoren in jeden Fertigungsprozess.

## STANDARD FUNCTIONS



**Pannello lcd multifunzione**  
(vedi pagina 13)  
*Multifunction LCD panel*  
(see page 13)



**Soft air elettronico**  
*Electronic soft air*

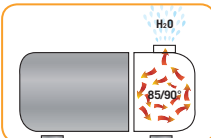

**Sistema autopulizia olio**  
*Oil made auto cleaning system*

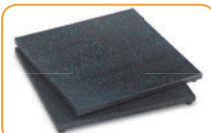

**Set tavole di riempimento in polietilene**  
*Polyethylene filling squares set*

## OPTIONALS



**Predisposizione al gas inerte**  
*Arrangement for idle gas*



**Installazione stampante**  
*Printer installation*



**Pompa Busch**  
*Busch Pump*



**Sensore di vuoto**  
*Vacuum sensor*



**Differente disposizione barre saldanti**  
*Different position of the sealing bars*

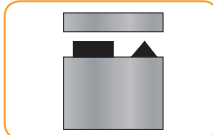

**Taglio Eccedenza**  
*Exceeding cutting bar*

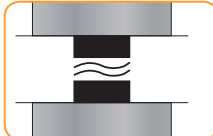

**Barra contrapposta biattiva**  
*Opposed sealing bar (beactive)*

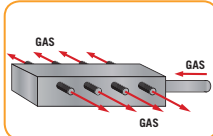

**Diffusore gas**  
*Gas diffuser*



**Pompa vuoto maggiorata**  
*Increased vacuum pump*

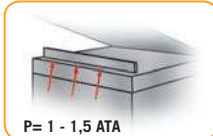

**Saldatura pneumatica**  
*Pneumatic sealing*

P= 1 - 1,5 ATA



**Tensione e frequenza speciale**  
*Voltage and speciale frequency*



# SUPER-TECH<sup>®</sup> SERIES



## MEGA



Rappresenta la soluzione ottimale per l'industria di medio grandi dimensioni che necessita di macchine a ciclo operativo continuativo o intermittente a seconda delle specifiche esigenze.

La flessibilità dell'apparecchiatura, la disposizione a scelta delle barre saldanti e la solidità strutturale di cui dispongono tutti i modelli collocano le confezionatrici mono-campana SUPER-TECH nei settori industriali più disparati con eccellenti risultati nei vari processi produttivi.



### DISPOSIZIONE BARRE SALDANTI / Sealing bars position

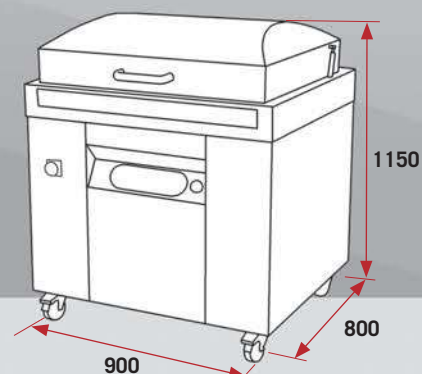
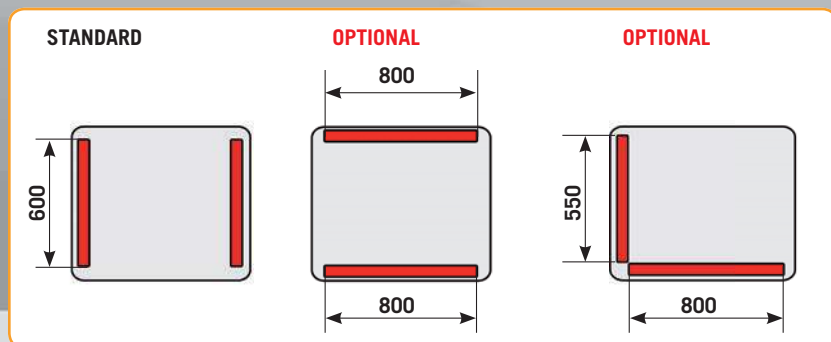

Modello model modèles modelo Modelle	Struttura structure structure estructura Struktur	Dim. d'ingombro overall dimension dim. d'encombrement dimensiones Abmessungen	Dimensioni camera size of the chamber dim. de la chambre dim. de la càmara Kammergröße	Barra saldante sealing bar barre de soudure barra soldante Schweißleiste	Pompa del vuoto vacuum pump pompe du vide bomba de vacío Vakuumpumpe	Peso weight poids peso Gewicht	Assorbimento absorption absorption consumo Aufsaugen	Tensione voltage voltage tensión Spannung
MEGA	inox	900x800x1150h	830x660x230h	2x(mm 600)	Q= 100/120 m <sup>3</sup> h-OIL	KG 220	W 2400	380 V/50-60 Hz



It's the optimum solution for the medium/large sized industry requiring for a vacuum packing machines with permanent of irregular working cycle, depending on its needs. The equipment flexibility, the placing of the sealing bars on request and the compactness granted for each model make this range of "SUPER-TECH" machines suitable to the most varied application fields with the best results.



Ces modèles représentent une très bonne solution pour l'industrie de moyennes/grandes dimensions, qui a nécessité d'un cycle opérationnel continu ou intermittent, selon les différentes exigences. La flexibilité des appareils, la disposition à votre choix des barres de soudure, et la solidité structurelle dont ils sont équipés, lui permettent de ce placer dans les plus différents secteurs d'usage, avec excellents résultats.



Estas maquinas son ideales para la industria medio – grande que necesita maquinas que trabajen de continuo o con pausas, según las exigencias. La flexibilidad del aparato, la posibilidad de elegir la posición de las barras soldantes y la solidez de la estructura hacen que todas las envasadoras mono-campana SUPER-TECH sean ideales para todos los diferentes sectores de la industria y que logren excelentes resultados en todos los procesos de producción.



Das ist die Lösung für die Medium /Grosse Firma, die dauerhaften Produktionsablauf braucht. Durch die Flexibilität der Apparatur, die Anordnung der Schweissleisten und die wichtige Struktur stellt diese „SUPERTECH“ Maschine mit dem bestem Resultaten in allen industriellen Sektoren in jeden Fertigungsprozess.

## STANDARD FUNCTIONS



**Pannello lcd multifunzione**  
(vedi pagina 13)  
*Multifunction LCD panel*  
(see page 13)



**Soft air elettronico**  
*Electronic soft air*



**Sistema autopulizia olio**  
*Oil made auto cleaning system*

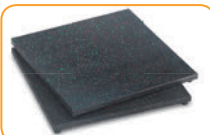

**Set tavole di riempimento in polietilene**  
*Polyethylene filling squares set*



## OPTIONALS



**Predisposizione al gas inerte**  
*Arrangement for idle gas*



**Installazione stampante**  
*Printer installation*



**Pompa Busch**  
*Busch Pump*



**Sensore di vuoto**  
*Vacuum sensor*

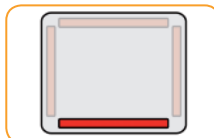

**Differente disposizione barre saldanti**  
*Different position of the sealing bars*

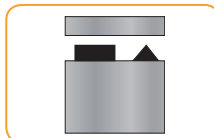

**Taglio Eccedenza**  
*Exceeding cutting bar*

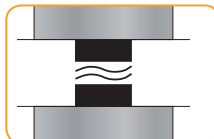

**Barra contrapposta biattiva**  
*Opposed sealing bar (beactive)*

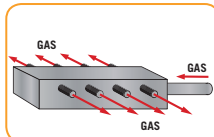

**Diffusore gas**  
*Gas diffuser*



**Pompa vuoto maggiorata**  
*Increased vacuum pump*



**Saldatura pneumatica**  
*Pneumatic sealing*

P= 1 - 1,5 ATA



**Tensione e frequenza speciale**  
*Voltage and speciale frequency*

# SUPER-TECH<sup>®</sup> SERIES



## JUMBO



Rappresenta la soluzione ottimale per l'industria di medio grandi dimensioni che necessita di macchine a ciclo operativo continuativo o intermittente a seconda delle specifiche esigenze. La flessibilità dell'apparecchiatura, la disposizione a scelta delle barre saldanti e la solidità strutturale di cui dispongono tutti i modelli collocano le confezionatrici mono-campana SUPER-TECH nei settori industriali più disparati con eccellenti risultati nei vari processi produttivi.



**JUMBO**

### DISPOSIZIONE BARRE SALDANTI / Sealing bars position

**STANDARD**

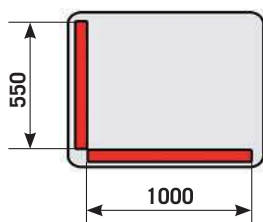

**OPTIONAL**

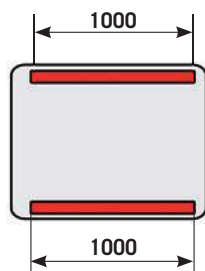

**OPTIONAL**

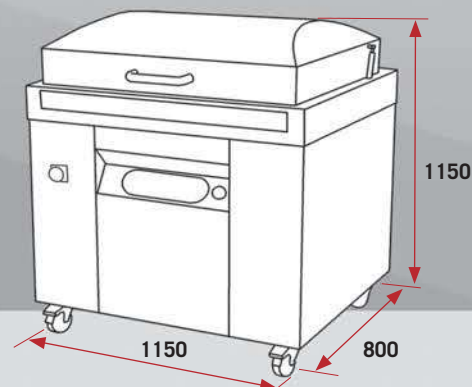
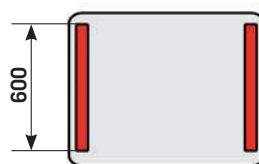

Modello model modèles modelo Modelle	Struttura structure structure estructura Struktur	Dim. d'ingombro overall dimension dim. d'encombrement dimensiones Abmessungen	Dimensioni camera size of the chamber dim. de la chambre dim. de la càmara Kammergröße	Barra saldante sealing bar barre de soudure barra soldante Schweißleiste	Pompa del vuoto vacuum pump pompe du vide bomba de vacío Vakuumpumpe	Peso weight poids peso Gewicht	Assorbimento absorption absorption consumo Aufsaugen	Tensione voltage voltage tensión Spannung
JUMBO	inox	1150x800x1150h	1050x660x230h	mm1000 / mm550	Q= 100/120 m <sup>3</sup> h-OIL	KG 250	W 2500	380 V/50-60 Hz



INOX | CE



It's the optimum solution for the medium/large sized industry requiring for a vacuum packing machines with permanent of irregular working cycle, depending on its needs. The equipment flexibility, the placing of the sealing bars on request and the compactness granted for each model make this range of "SUPER-TECH" machines suitable to the most varied application fields with the best results.



Ces modèles représentent une très bonne solution pour l'industrie de moyennes/grandes dimensions, qui a nécessité d'un cycle opérationnel continu ou intermittent, selon les différentes exigences. La flexibilité des appareils, la disposition à votre choix des barres de soudure, et la solidité structurelle dont ils sont équipés, lui permettent de ce placer dans les plus différents secteurs d'usage, avec excellents résultats.



Estas máquinas son ideales para la industria medio - grande que necesita máquinas que trabajen de continuo o con pausas, según las exigencias. La flexibilidad del aparato, la posibilidad de elegir la posición de las barras soldantes y la solidez de la estructura hacen que todas las envasadoras mono-campana SUPER-TECH sean ideales para todos los diferentes sectores de la industria y que logren excelentes resultados en todos los procesos de producción.



Das ist die Lösung für die Medium / Grosse Firma, die dauerhaft/ ruckartig Produktionsablauf braucht. Durch die Flexibilität der Apparatur, die Anordnung der Schweissleisten und die wichtige Struktur stellt diese „SUPERTECH“ Maschine mit dem bestem Resultaten in allen industriellen Sektoren in jeden Fertigungsprozess.

## STANDARD FUNCTIONS



**Pannello lcd multifunzione**  
(vedi pagina 13)  
*Multifunction LCD panel*  
(see page 13)



**Soft air elettronico**  
*Electronic soft air*

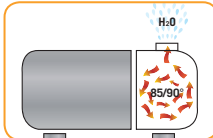

**Sistema autopulizia olio**  
*Oil made auto cleaning system*

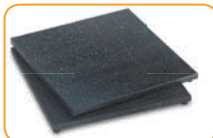

**Set tavole di riempimento in polietilene**  
*Polyethylene filling squares set*



## OPTIONALS



**Predisposizione al gas inerte**  
*Arrangement for idle gas*



**Installazione stampante**  
*Printer installation*



**Pompa Busch**  
*Busch Pump*



**Sensore di vuoto**  
*Vacuum sensor*



**Differente disposizione barre saldanti**  
*Different position of the sealing bars*

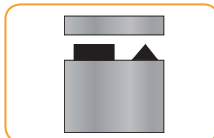

**Taglio Eccedenza**  
*Exceeding cutting bar*

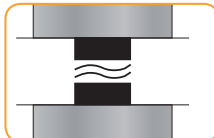

**Barra contrapposta biattiva**  
*Opposed sealing bar (beactive)*

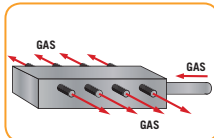

**Diffusore gas**  
*Gas diffuser*



**Pompa vuoto maggiorata**  
*Increased vacuum pump*

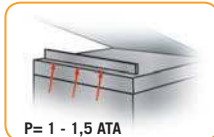

**Saldatura pneumatica**  
*Pneumatic sealing*

P= 1 - 1,5 ATA



**Tensione e frequenza speciale**  
*Voltage and speciale frequency*

# SUPER-TECH<sup>®</sup> SERIES



## JUMBO SUPER



Rappresentano la soluzione ideale per l'azienda che necessita di un'apparecchiatura altamente produttiva e flessibile al confezionamento di qualsiasi prodotto. L'elevata potenza della pompa del vuoto, la lunghezza delle barre saldanti e la flessibilità nella disposizione di queste, unitamente ad un volume di camera veramente sorprendente collocano con successo la confezionatrice JUMBO SUPER nei più svariati settori dell'industria alimentare



**JUMBO SUPER**

### DISPOSIZIONE BARRE SALDANTI / Sealing bars position

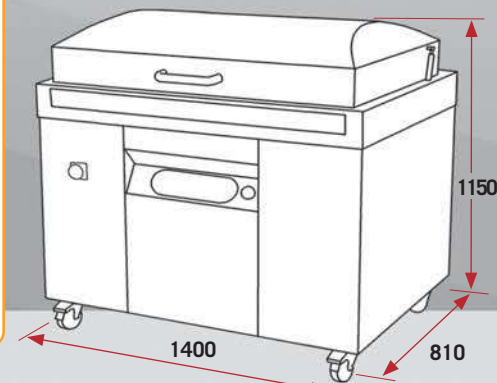
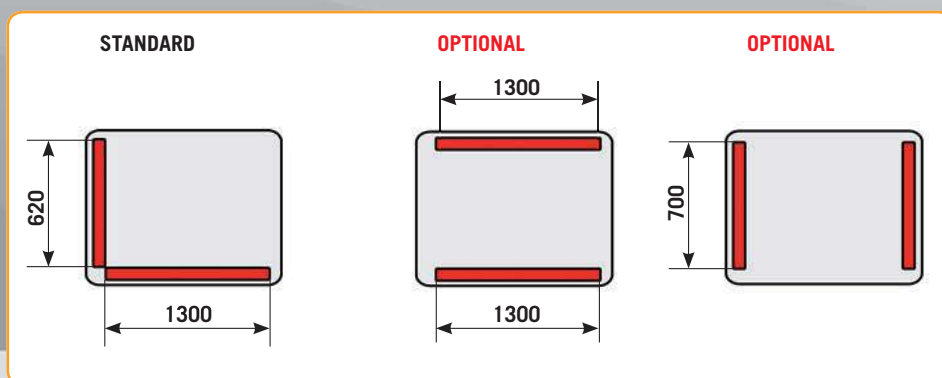

Modello model modèles modelo Modelle	Struttura structure structure estructura Struktur	Dim. d'ingombro overall dimension dim. d'encombrement dimensiones Abmessungen	Dimensioni camera size of the chamber dim. de la chambre dim. de la càmara Kammergröße	Barra saldante sealing bar barre de soudure barra soldante Schweißleiste	Pompa del vuoto vacuum pump pompe du vide bomba de vacío Vakuumpumpe	Peso weight poids peso Gewicht	Assorbimento absorption absorption consumo Aufsaugen	Tensione voltage voltage tensión Spannung
JUMBO SUPER	inox	1400x810x1150h	1310x710x320h	mm1300 / mm620	Q= 150/180 m <sup>3</sup> h-OIL	KG 320	W 2500	380 V/50-60 Hz



INOX | CE



Jumbo Super is ideal for companies who need high-production equipment to pack any product.

Thanks to its high-capacity vacuum pump, length of sealing bars and their changeable position, Jumbo Super is suitable for all food industry sectors, as it enables the packaging of high loading volumes.



Ce sont la solution idéale pour qui l'activité qui a besoin d'une machine ayant un haut taux de productivité et en mesure d'emballer sous vide n'importe quel produit.

L'extrême puissance de la pompe de vide, la longueur des barres de soudure ainsi que leur grande flexibilité d'arrangement dans la cuve, sans oublier la possibilité de charger des produits vraiment volumineux, permettent à notre machine sous vide JUMBO SUPER de s'imposer avec succès parmi les différents secteurs de l'industrie alimentaire.



La gran potencia de la bomba de vacío, el largo de las barras soldantes y la posibilidad de elegir posiciones diferentes de las mismas con respecto al catálogo, junto a un volumen de carga sorprendente hacen que la envasadora JUMBO SUPER pueda trabajar en todos los sectores de la industria alimentar.



Es ist die perfekte Lösung für Firmen, die sehr produktive und flexible Geräte brauchen, die verschiedene Produkte verpacken können. Die hohe Leistung der Pumpe, die Länge der Schweissbalken und die Flexibilität in sie zu positionieren zusammen mit der herausragenden Kammergröße erlauben der JUMBO SUPER in vielen Branchen der Lebensmittelindustrie verwendet zu werden.

## STANDARD FUNCTIONS



**Pannello lcd multifunzione**  
(vedi pagina 13)  
*Multifunction LCD panel*  
(see page 13)



**Soft air elettronico**  
*Electronic soft air*

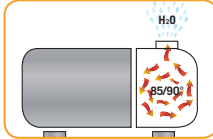

**Sistema autopulizia olio**  
*Oil made auto cleaning system*

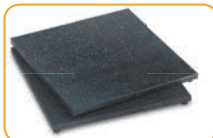

**Set tavole di riempimento in polietilene**  
*Polyethylene filling squares set*



## OPTIONALS



**Predisposizione al gas inerte**  
*Arrangement for idle gas*



**Installazione stampante**  
*Printer installation*



**Pompa Busch**  
*Busch Pump*



**Sensore di vuoto**  
*Vacuum sensor*



**Differente disposizione barre saldanti**  
*Different position of the sealing bars*

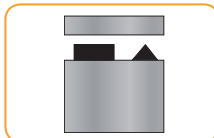

**Taglio Eccedenza**  
*Exceeding cutting bar*



**Barra contrapposta biattiva**  
*Opposed sealing bar (beactive)*

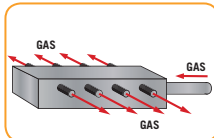

**Diffusore gas**  
*Gas diffuser*



**Pompa vuoto maggiorata**  
*Increased vacuum pump*

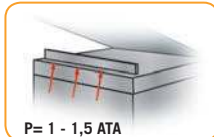

**Saldatura pneumatica**  
*Pneumatic sealing*

P= 1 - 1,5 ATA



**Tensione e frequenza speciale**  
*Voltage and speciale frequency*



SUPERMEGA

## SUPERMEGA



Costruita secondo i canoni della qualità e dell'affidabilità la doppia campana della serie SUPER-TECH è stata concepita per gestire quantità e continuità nei vari settori d'utilizzo. E' possibile configurare la confezionatrice con differenti soluzioni saldanti (mono-saldatura, saldatura biattiva) e differenti pompe per il vuoto operanti a ciclo continuo o alternato. E' possibile l'affiancamento a rulliera di scarico fissa.

### STANDARD

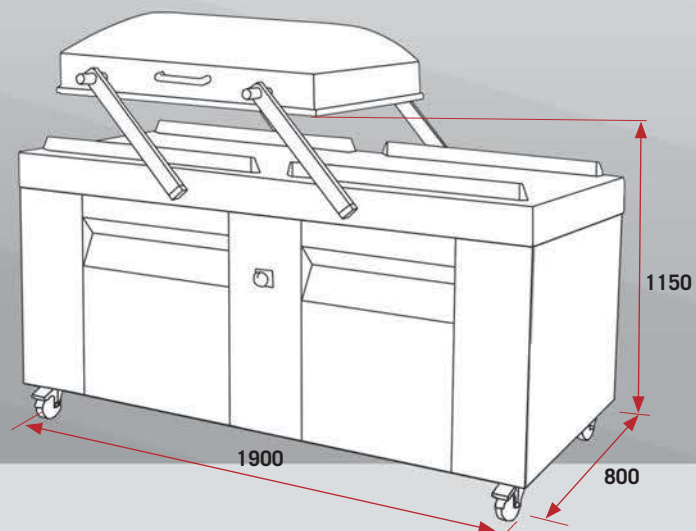
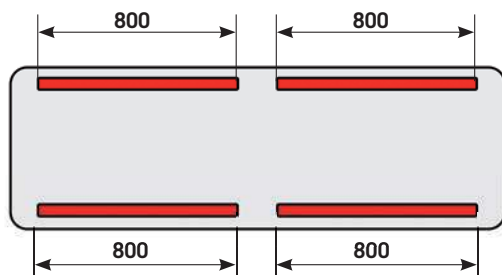

Modello model modèles modelo Modelle	Struttura structure structure estructura Struktur	Dim. d'ingombro overall dimension dim. d'encombrement dimensiones Abmessungen	Dimensioni camera size of the chamber dim. de la chambre dim. de la cámara Kammergröße	Barra saldante sealing bar barre de soudure barra soldante Schweißleiste	Pompa del vuoto vacuum pump pompe du vide bomba de vacío Vakuumpumpe	Peso weight poids peso Gewicht	Assorbimento absorption absorption consumo Aufsaugen	Tensione voltage voltage tensión Spannung
SUPERMEGA	inox	1900x800x1150h	2x(830x740x230h)	4x(mm 800)	Q= 100/120 m <sup>3</sup> h-OIL	KG 360	W 2700	380 V/50-60 Hz



INOX | CE



Totally assembled according to high quality criteria and reliability, this double chamber SUPER-TECH machine's conceived to grant both quantity and continuity in all the varied application fields.

It is possible to customize this machine by choosing different sealing solutions (Single or double sealing bar) and different vacuum pumps.

It is also possible to place a fixed unloading roller side by side.

Construite selon les principes de la qualité et la fiabilité, la double cloche de la série SUPER-TECH à été pensée pour gérer quantité et continuité dans les différents secteurs d'usage. Il est possible régler l'appareil selon différents solutions de soudure (mono soudure, soudure biactive) et différentes pompes de vide, à cycle continu ou alterné. De plus, il est possible l'utiliser à coté d'une machine avec rouleau fixe de décharge produits.

Se fabrica según el estándar de calidad y fiabilidad de la gama SUPER-TECH. Esta doble campana nació para poder envasar muchas cantidades de continuo en los diferentes sectores de utilización. se pueden personalizar las maquinas con diferentes soluciones de sellado ( mono - soldadura, doble soldadura ) y diferentes bombas de vacío que pueden trabajar a ciclo continuo o alterno. La maquina se puede poner cerca de un rollo fijo de descargue productos.

Es wird mit der besser Qualität und Sicherheit herstellt; diese doppelte Maschine kann für Menge und Kontinuität in jeden Verwendungssektor bürgen.

Es ist möglich, die Maschine mit verschiedenen Schweißungs-Lösungen und verschiedenen Vakuumpumpen zu bestimmen.

Es ist auch möglich, eine Abladensrolle zur Seite der Maschine zu stellen.

## STANDARD FUNCTIONS



**Pannello lcd multifunzione**  
(vedi pagina 13)  
*Multifunction LCD panel*  
(see page 13)



**Soft air elettronico**  
*Electronic soft air*

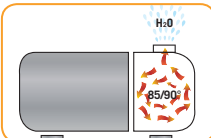

**Sistema autopulizia olio**  
*Oil made auto cleaning system*



**Set tavole di riempimento in polietilene**  
*Polyethylene filling squares set*

## OPTIONALS



**Predisposizione al gas inerte**  
*Arrangement for idle gas*



**Installazione stampante**  
*Printer installation*



**Pompa Busch**  
*Busch Pump*



**Sensore di vuoto**  
*Vacuum sensor*

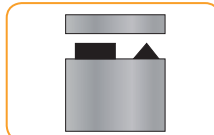

**Taglio Eccedenza**  
*Exceeding cutting bar*

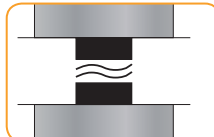

**Barra contrapposta biattiva**  
*Opposed sealing bar (beactive)*

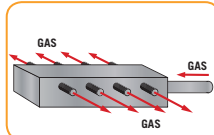

**Diffusore gas**  
*Gas diffuser*



**Pompa vuoto maggiorata**  
*Increased vacuum pump*

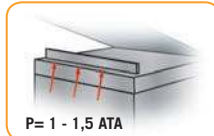

**Saldatura pneumatica**  
*Pneumatic sealing*

P= 1 - 1,5 ATA



**Tensione e frequenza speciale**  
*Voltage and speciale frequency*

# SUPER-TECH SERIES



## PANNELLO COMANDI / control panel

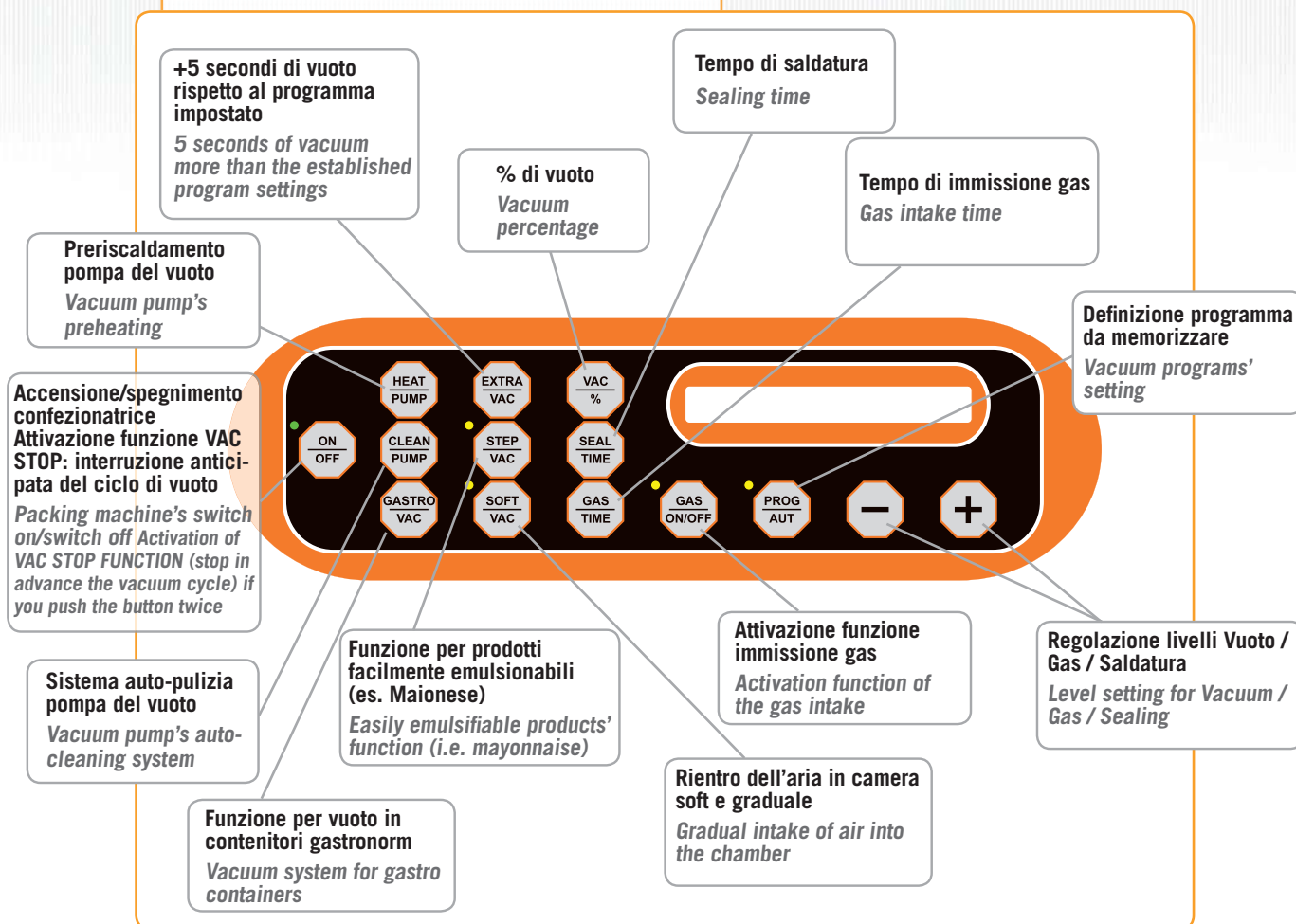

**SUPER  
TECH**





---

**COTTURA A BASSA  
TEMPERATURA**

**LOW COOKING  
TEMP SYSTEMS**

**SYSTÈMES DE CUISSON  
À BAISSÉ TEMPERATURE**

**APARATOS PARA LA COCCIÒN AL  
VACÌO A BAJAS TEMPERATURAS**

**NIEDRIGTEMPERATUR-  
KOCHSYSTEM**



COTTURA A BASSA TEMPERATURA  
low cooking temp systems

SOUS VIDE Series

PAG 70



CVS 200  
CVS 400  
CVS 800

LEGENDA SIMBOLI:



Costruito nel rispetto dell'ambiente  
*Environment friendly manufactured*  
*Construit en respectant l'environnement*  
*Fabricado respetando el ambiente*  
*Umweltfreundliche Herstellung*



Ideale per ristoranti  
*Suitable for restaurants*  
*Idéels pour restaurants*  
*Idéal para restaurantes*  
*Idéal für Restaurants*



Ideale per alimentari e gastronomie  
*Suitable for food shops and delicatessen*  
*Idéal pour alimentaires et gastronomies*  
*Idéal para detallantes y gastronomías*  
*Idéal für lebensmittelverarbeitende Betriebe und Gastronomie*

MADE IN ITALY

# SOUS VIDE SERIES

**CVS 800**

**CVS 400**

**CVS 200**

Modello model modèles modelo Modelle	Dimensioni d'ingombro overall dimension dim. d'encombrement dimensiones Größe	H totale vasca total chamber height hauteur total de la cuve altura total de la cuba gesamte kammerhöhe	H livello H <sub>2</sub> O effective water level hauteur niveau H <sub>2</sub> O (eau) altura nivel H <sub>2</sub> O effektiver Wasserstand	Capacità max vasca maximum chamber capacity capacité max de la cuve maxima capacidad cuba Maximum Kammer-Fassungsvermögen	Temperatura di lavoro working temperature temperature de travail temperatura de trabajo Betriebstemperatur	Potenza puissance power potencia Leistung	Peso weight poids peso Gewicht	Tensione voltage voltage tensión Spannung
CVS 200	345x285x270H	mm 150	mm 120	9 LITRI	45° - 100°	400 W	KG 6,5	230 V/50-60 Hz
CVS 400	350x550x320H	mm 200	mm 170	25 LITRI	45° - 100°	1000 W	KG 12	230 V/50-60 Hz
CVS 800	670x550x320H	mm 200	mm 170	50 LITRI	45° - 100°	2000 W	KG 20	230 V/50-60 Hz

## CVS 200 / CVS 400 / CVS 800



Si tratta di un innovativo strumento per la cottura in sottovuoto a bassa temperatura degli alimenti. Il ciclo di lavoro di questa nuova apparecchiatura si caratterizza di due fasi distinte: in una prima fase viene impostata dall'operatore la temperatura desiderata dell'acqua in vasca (normalmente non superiore ai 60°) ed una seconda fase in cui viene impostato il tempo di cottura. La staticità dell'acqua unitamente ad un continuo monitoraggio, attraverso sensore, del mantenimento di una temperatura uniforme in vasca, consentono alla macchina di operare una tipologia di cottura che attribuisce ai prodotti un'estrema morbidezza interna, l'esaltazione dei sapori oltre ad una riduzione evidente del "calo peso" durante lo stesso processo di cottura. Proprio per queste ragioni il nuovo SOUS VIDE SYSTEM è ormai uno strumento di lavoro indispensabile all'interno di qualsiasi cucina professionale



SOUSVIDE SYSTEM is the innovative device to cook at low temperature all kind of food products packed in vacuum bags. The working cycle of this new equipment is characterized by two distinct phases: the operator can set the desired temperature of the water in the tank through the control board (normally temp won't be set higher than 60 °) and at a second stage, he may set the cooking time. The static water together with the constant monitoring through the sensor/ probe - which helps keeping the temperature uniform and constant in the bath - allow to reach excellent cooking results: food is extremely soft and tasty, flavours are exalted and 'weight loss' will be definitely reduced. That is why, our SOUSVIDE SYSTEM is considered the essential tool for any professional kitchen.



il s'agit d'un nouveau appareil pour la cuisson à basse température des aliments. le cycle de travail de cette nouvelle machine es caracterisé par deux différents moments: dans un premier temps l'opérateur règle la température de l'eau dans la cuve (généralement jamais supérieur aux 60°), après il règle le temps de cuisson. La capacité de l'appareil de garder statique l'eau et de vérifier en continu, avec le senseur, que la température dans la cuve soit toujours uniforme, garantissent une typologie de cuisson qui donne aux produits une énorme douceur à l'intérieur, l'exaltation des saveurs et une évidente réduction de perte de poids pendant le processus de cuisson. pour toutes cettas raisons le nouveau SYSTEME SOUS VIDE es devenu une machine indispensable dans toutes cuisines professionnelles.



Se trata de un método innovador para la cocción al vacío a baja temperatura de los alimentos. El ciclo de trabajo de este nuevo equipo se caracteriza por tener dos fases diferentes : en la primera el operador selecciona la temperatura del agua deseada en la cuba (generalmente no más de 60°) y en la segunda se selecciona el tiempo de cocción. El estatismo del agua junto al control constante de la temperatura uniforme en la cuba, a través de un sensor, permite al sous vide de hacer un tipo de cocción que atribuye a los productos más blandura interior, exaltación de los sabores y reducción de la "pérdida de peso" durante la misma cocción. Por eso el nuevo SOUS VIDE SYSTEM es un equipo fundamental en todas las cocinas profesionales



Es handelt sich um ein innovatives Niedrigtemperatur-Kochsystem für vakuumierte Produkte. Der Arbeitsablauf dieser Gerät besteht sich aus zwei verschiedenen Phasen: in der erste wird die Temperatur vom Benutzer eingestellt (normalerweise nicht auf 60°) und in der zweite wird die Kochzeit eingestellt. Die Wasserstarrheit, zusammen mit der kostanten Kontrolle der Temperatur in der Kammer durch einen Sensor, erlauben die Produkte mit einer besonderen Technik zu kochen, die sie extrem weich hält, den Geschmack aufregt und den Verlust von Gewicht der Produkte reduziert. Aus diesem Grund wird der SOUS VIDE SYSTEM immer wichtiger für die professionelle Köcher

COTTURA A BASSA TEMPERATURA  
low cooking temp systems

CVS 800

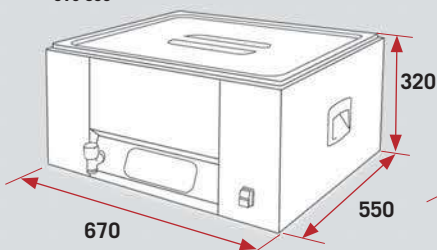

CVS 400

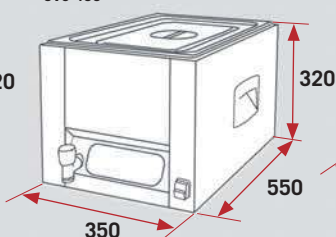

CVS 200

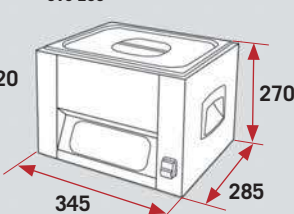

INOX CE



# SOUS VIDE SERIES

## PANNELLO COMANDI / control panel

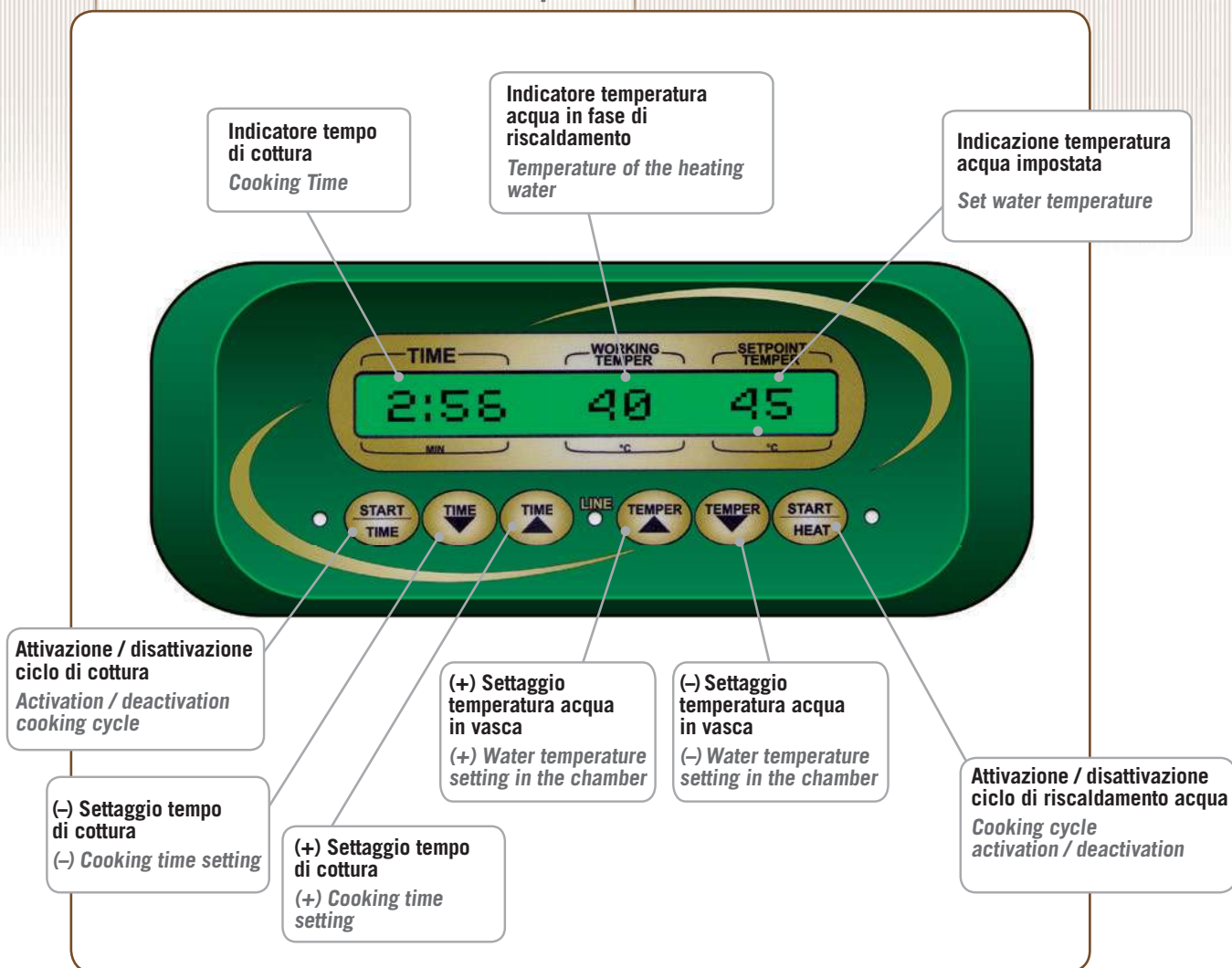



**SPEEDY**



**CVS 800**

COTTURA A BASSA TEMPERATURA  
low cooking temp systems



---

**TERMOSIGILLATRICI  
PER VASCHE**

**TRAYSEALERS**

**THERMOSCELLEUSES  
POUR BARQUETTES**

**TERMOSELLADORAS  
PARA BANDEJAS**

**SIEGELGERÄTE**



TERMOPACK Series PAG 76



SV 300  
SV 400

PACKMATIC Series PAG 78



PACKMATIC 300  
PACKMATIC 400

TERMOVAC Series PAG 80



VG 600  
VG 800



TERMOGILLATRICI PER VASCHETTE  
traysealers

LEGENDA SIMBOLI:



Costruito nel rispetto dell'ambiente  
*Environment friendly manufactured*  
*Construit en respectant l'environnement*  
*Fabricado respetando el ambiente*  
*Umweltfreundliche Herstellung*



Ideale per ristoranti  
*Suitable for restaurants*  
*Idéels pour restaurants*  
*Ideal para restaurantes*  
*Ideal für Restaurants*



Ideale per alimentari e gastronomie  
*Suitable for food shops and delicatessen*  
*Idéal pour alimentaires et gastronomies*  
*Ideal para detallantes y gastronomías*  
*Ideal für lebensmittelverarbeitende Betriebe und Gastronomie*



Ideale per pasticcerie e panificazione  
*Perfect for confectioner's*  
*Idéal pour la pâtisserie*  
*Perfecto para pastelerías*  
*Ideal für Konditoreien*

MADE IN ITALY

# TERMOPACK SERIES

**SV 300**

**SV 400**
**SV 300**

**STAMPO MV**  
 MOULD MV 138X96

**STAMPO MV 193X138**  
 MOULD MV 193X138

**STAMPO MV 180X180**  
 MOULD MV 180X180

**STAMPO MV 195X260**  
 MOULD MV 195X260

**SV 400**

**STAMPO GN 1/2**  
 mm 265X320  
 MOULD GN 1/2  
 mm 265X320

**STAMPO GN 1/4**  
 mm 265X160  
 MOULD GN 1/4  
 mm 265X160

**STAMPO GN 1/8**  
 mm 160X130  
 MOULD GN 1/8  
 mm 160X130

**STAMPO GN**  
 2 X (180X180)  
 MOULD GN  
 2 X (180X180)

Modello models modèles modelos Modelle	Dimensioni d'ingombro overall dimension dim. d'encombrement dimensiones Größe	Dimen. max. contenitore maximum container dimension dimension maximum du pot dimension maxima contenedor Maximum Behälter Dimension	Potenza installata installed power puissance installée potencia instalada Installiert Macht	Ciclo di lavoro working cycle cycle de travail ciclo de trabajo Arbeitszyklus	Pompa del vuoto vacuum pump pompe du vide bomba de vacío Vakuumpumpe	Comandi controls commandes mandos Anschaltung	Press. max. max. pressure pression maximale máxima presión Maximaler Druck	Tensione voltage voltage tension Spannung
SV 300 <sub>digit</sub>	mm 280x500x600H open	mm 265x196	600 W	manual	-	digit	-	230 V/50-60 Hz
SV 400 <sub>digit</sub>	mm 400x500x600H open	mm 265x325	1200 W	manual	-	digit	-	230 V/50-60 Hz

## SV 300 / SV 400

Termosigillatrici semi automatiche per il confezionamento di prodotti in vaschetta. Attraverso questa tipologia di confezionatrici è possibile sigillare, in maniera igienica e ineccepibile prodotti in vaschetta al fine di migliorare la conservazione e soprattutto proporle all'utente finale in un involucro rigido e perfettamente sigillato.

Attraverso questa linea di confezionatrici si persegue un obiettivo primario di confezionamento non di conservazione in quanto la termosigillatrice non pone le vaschette in sottovuoto.



## PANNELLO COMANDI/control panel

Tasto accensione quadro comandi  
Control panel switch on/off

Display  
Display

Aumento valori tempo / temperatura  
Time / temperature increase

Tasto settaggio tempo / temperatura  
Time / temperature setting

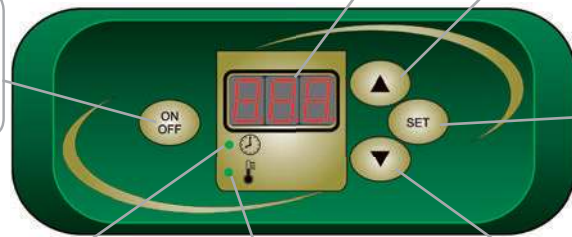

Led tempo di saldatura  
Sealing time led

Led termocoppia resistenza  
Thermocouple resistance led

Diminuzione valori tempo / temperatura  
Time / temperature decrease



Rulli supporto bobina  
Roll support

Semi-automatic thermosealer to pack food in tray. Packing in trays is the most properly hygienic and good looking solution to offer to final customers any product in its perfectly sealed case. It's important to underline that these machines do not vacuum pack trays and their aim isn't the food preservation rather than its correct packing.

Termoschelleuses semi automatiques pour le conditionnement des produits en barquette. Grâce à cette typologie de machines il est possible sceller, dans une façon hygienique et irréprochable, les produits en barquette pour améliorer la conservation et surtout pour les proposer au client final dans un enveloppe rigide et bien scellé. Cette gamme de termoschelleuses poursuivre le but primaire de conditionnement et pas de conservation, car les appareils ne mettent pas les barquettes sous vide.

Termoselladoras semi - automaticas para envasar productos en barquetas. Gracias a estas termoselladoras se pueden sellar, de manera higienica, productos en cubetas para mejorar la conservación y sobretodo entregarlos al consumidor en un paquete rigido y perfectamente sellado.

Utilizando esta gama de selladoras el objetivo principal es lo de empaquetar, no lo de conservar, porque la termoselladora no hace el vacio.



Halbautomatische Thermoversiegler für Schalen Dank dieser Geräte ist es möglich Schalen sauber, hygienisch und einwandfrei zu verschweissen. Dadurch wird die Haltbarkeit verbessert und der Kunde hat immer die Sicherheit ein sauber verschlossenes Produkt in robuster Schalenverpackung erhalten zu haben. Ziel dieser Geräte ist die saubere und einwandfreie Verpackung, nicht so sehr aber eine Verlängerung der Haltbarkeit da diese Geräte kein Vakuum erzeugen.

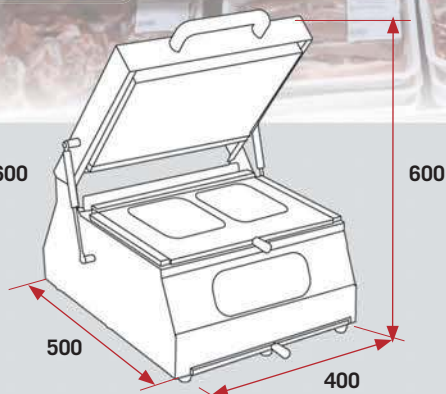

INOX | CE

# PACKMATIC SERIES



**PACKMATIC 400**



**PACKMATIC 300**

## PACKMATIC 300



STAMPO MV  
MOULD MV 138X96

STAMPO MV 193X138  
MOULD MV 193X138

STAMPO MV 180X180  
MOULD MV 180X180

STAMPO MV 195X260  
MOULD MV 195X260

## PACKMATIC 400



STAMPO GN 1/2  
mm 265X320  
MOULD GN 1/2  
mm 265X320

STAMPO GN 1/4  
mm 265X160  
MOULD GN 1/4  
mm 265X160

STAMPO GN 1/8  
mm 160X130  
MOULD GN 1/8  
mm 160X130

STAMPO GN  
2 X (180X180)  
MOULD GN  
2 X (180X180)

Modello models modèles modelos Modelle	Dimensioni d'ingombro overall dimension dim. d'encombrement dimensiones Größe	Dimen. max. contenitore maximum container dimension dimension maximum du pot dimension maxima contenedor Maximum Behälter Dimension	Potenza installata installed power puissance installée potencia instalada Installiert Macht	Ciclo di lavoro working cycle cycle de travail ciclo de trabajo Arbeitszyklus	Pompa del vuoto vacuum pump pompe du vide bomba de vacío Vakuumpumpe	Comandi controls commandes mandos Anschaltung	Press. max. max. pressure pression maximale máxima presión Maximaler Druck	Tensione voltage voltage tension Spannung
PACKMATIC300	mm 340x600x620H	mm 265x196	600 W	semi-automatic	-	digit	-	230 V/50-60 Hz
PACKMATIC400	mm 500x600x620H	mm 265x325	1200 W	semi-automatic	-	digit	-	230 V/50-60 Hz

# PACKMATIC 300 / PACKMATIC 400



Termosigillatrici con ciclo di lavoro semiautomatico per il confezionamento di prodotti in vaschetta. Queste apparecchiature ideali per supermercati e laboratori di gastronomia consentono, grazie alla propria versatilità, un'ottimale sigillatura su qualsiasi tipologia di vaschetta. Le confezionatrici in oggetto infatti sono dotate di un sistema di pressione della piastra saldante perfettamente bilanciata che, unitamente all'assenza totale di "parti riscaldanti esposte", assicurano ottime prestazioni, elevato rendimento preservando nel contempo la totale sicurezza dell'operatore.



Semi-automatic tray-sealers for the vacuum packaging of food products. These machines represent the ideal solution for supermarkets and delicatessen stores because, thanks to their versatility, they can vacuum pack and properly seal on to a wide range of trays. These tray-sealers are equipped with a perfect balanced sealing plate's pressure system with no 'exposed heating elements', which enables an excellent performance, granting high security levels for the operators.



Thermoscellieuses avec cycle de travail semi-automatique, pour le conditionnement des produits en baquettes. Ces appareils idéels pour supermarchés et laboratoires de gastronomie permettent, grâce à leur versatilité, une soudure parfaite pour toutes typologies de barquettes. Ils sont, en effet, équipés d'un système de pression de la plaque de soudure parfaitement balancé qui, grâce à l'absence total de "parties chauffantes exposées", garantit une prestation optimale et une excellente performance, en préservant au même temps la sécurité de l'utilisateur.



Termoselladoras con ciclo de trabajo semiautomático para envasar productos en recipientes. Estos aparatos son ideales para supermercados y gastronomías y pueden sellar perfectamente cualquier tipo de bandeja, gracias a su versatilidad. Estas termoselladoras tienen un sistema de presión de la plancha soldante perfectamente equilibrada que, junto al hecho que no hay partes calientes a la vista, garantizan óptimo rendimiento, asegurando la seguridad del usuario.

## PANNELLO COMANDI/control panel

Tasto accensione quadro comandi  
Control panel switch on/off

Display  
Display

Aumento valori tempo / temperatura  
Time / temperature increase

Tasto settaggio tempo / temperatura  
Time / temperature setting

Led tempo di saldatura  
Sealing time led

Led termocoppia resistenze  
Thermocouple resistance led

Diminuzione valori tempo / temperatura  
Time / temperature decrease

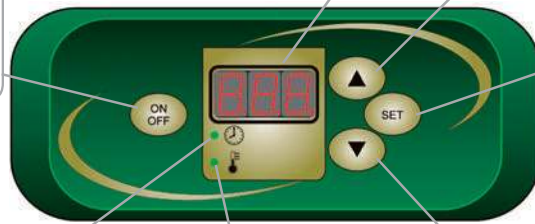

## HALBAUTOMATISCHE THERMOSCHWEISSGERÄTE UM PRODUKTE IN SCHALEN ZU VERPACKEN

Diese Geräte sind ideal für Supermärkte und kleine Geschäfte und erlauben alle Schalentypen zu schweissen.

Diese Schweissgeräte haben ein sehr balanciertes Drucksystem für die Platte, das, zusammen mit der Abwesenheit von ausgesetzten Heizelementen, eine sehr gute Leistung garantiert, ohne die Arbeitersicherheit zu vernachlässigen.

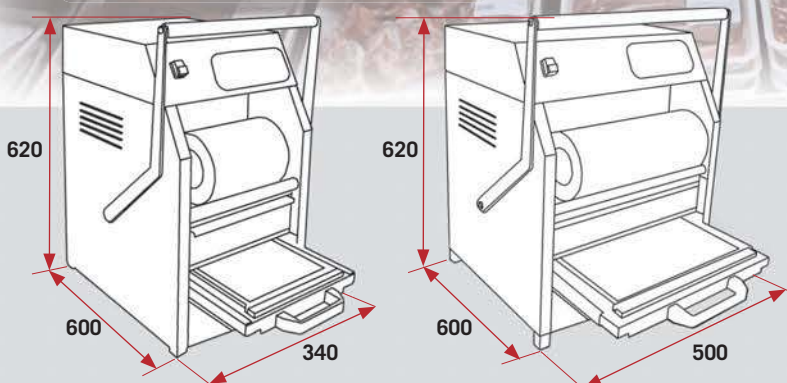

**VG 800**

**VG 600**

**STAMPO GN 1/2 mm 265X320**  
**MOULD GN 1/2 MM 265X320**

**STAMPO GN 1/4 mm 265X160**  
**MOULD GN 1/4 MM 265X160**

**STAMPO GN 1/8 mm 160X130**  
**MOULD GN 1/8 MM 160X130**

Modello models modèles modelos Modelle	Dimensioni d'ingombro overall dimension dim. d'encombrement dimensiones Größe	Dimen. max. contenitore maximum container dimension dimension maximum du pot dimension maxima contenedor Maximum Behälter Dimension	Potenza installata installed power puissance installée potencia instalada Installiert Macht	Ciclo di lavoro working cycle cycle de travail ciclo de trabajo Arbeitszyklus	Pompa del vuoto vacuum pump pompe du vide bomba de vacío Vakuumpumpe	Comandi controls commandes mandos Anschaltung	Press. max. max. pressure pression maximale máxima presión Maximaler Druck	Tensione voltage voltage tension Spannung
VG 600 <sub>LD</sub>	mm 610x600x560H	mm 265x325	1800 W	automatic	Q= 20/24 m <sup>3</sup> h-OIL	digit LCD + sensor-VAC	3/4 BAR	230 V/50-60 Hz
VG 800 <sub>LD</sub>	mm 610x600x1100H	mm 265x325	1800 W	automatic	Q= 20/24 m <sup>3</sup> h-OIL	digit LCD + sensor-VAC	3/4 BAR	230 V/50-60 Hz

## VG 600 / VG 800



La linea Termovac propone due modelli di termosigillatrici per vaschette estremamente utili per piccoli e medi laboratori e supermarket che intendono intraprendere il confezionamento sottovuoto di vaschette (150/300 vaschette al giorno). Il funzionamento di queste termosigillatrici si sviluppa in tre step di lavorazione:

- Creazione vuoto in camera: fase svuotamento
- Iniezione gas inerte per compensazione: fase immissione gas
- Sigillatura ermetica delle vaschette: fase di sigillatura

Naturalmente queste fasi vengono eseguite in totale autonomia dalla confezionatrice stessa che interrompe l'attività solo a conclusione di tutte e tre gli step di lavorazione.

I Modelli presentati sono di ultima generazione con saldatura pneumatica con pistone 3BAR e sensore di vuoto VACUUM-GAS.



"Termovac" line of two thermosealers is strongly recommended for all those small/medium workrooms interested in vacuum packing their own production in trays. A complete working cycle follows three simple steps:

- Creation of the vacuum inside the chamber: download phase
- Idle gas injection for compensation: gas injection phase
- Trays airtight sealing : sealing phase

These three steps are naturally put into execution by the thermo-sealer itself, which automatically stops at the end of the working cycle only.

Both models are in the latest version, with the brand new pneumatic sealing by a 3BAR piston and specific VACUUM-GAS sensor on the electronic board.



La ligne Termovac propose deux modèles de termoschelleuses pour barquettes vraiment utiles pour les petits et moyens laboratoires qui souhaitent engager le conditionnement sous vide en barquettes. Le fonctionnement de cetttes machines se développe en trois step de travail:

- Création du vide dans la chambre: phase de desamorcement
- Injection de gaz inerte pour compensation: phase d'injection gaz
- Soudure hérmétique des barquettes: phase de soudure

La machine développe cetttes trois phases en pleine autonomie, et elle n'arrête son activité que à conclusion de touts les trois steps de travail.

Les modèles présentés seront de dernière génération, avec soudure pneumatique avec piston 3 BAR et senseur de vide VACUUM-GAS



Die Serie Termovac besteht aus zwei Modellen von Thermoversiegeln für Schalen, die besonders für kleine, mittlere Betriebe und Supermärkte geeignet sind die täglich ca. 150 / 300 Schalen am Tag versiegeln und vakuumieren wollen. Die Funktionsweise dieser Geräte:

- Vakuumieren: Luft wird entzogen
- Gas wird hinzugegeben und kompensiert die entzogene Luft
- Versiegelung: Verschließt die Schalen sauber und hygienisch

Selbstverständlich laufen diese drei Schritte vollkommen automatisch ab und der Bediener braucht dann die fertigen Schalen nur mehr zu entnehmen und neue hinzuzugeben.

Diese Modelle entsprechen der neuesten Generation mit pneumatischer Schweissung mit 3 Bar und einem Vakuum-Gas Sensor.



la gama termovac tiene 2 modelos de termoselladoras para cubetas muy útiles para pequeños y medianos obradores y gastronomías que necesitan envasar cubetas al vacío. El funcionamiento de estas máquinas es caracterizado de 3 etapas de trabajo:

- Creación vacío dentro de la cámara
- Sellado hermético de las bandejas: etapa de sellado
- Inyección gas alimentar por compensación

Claramente estas 3 etapas son realizadas automáticamente de la termoselladora que se para solamente cuando las 3 etapas del ciclo de trabajo se han terminado.

Los modelos ofertados son los más actualizados, con sellado neumático con pistón de 3 BAR y sensor de vacío VACUUM - GAS.

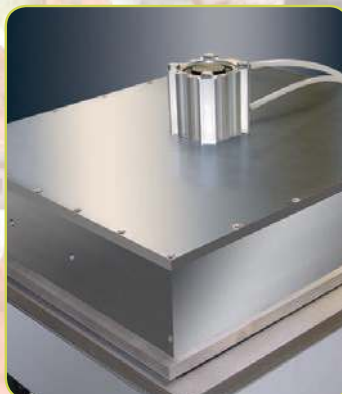
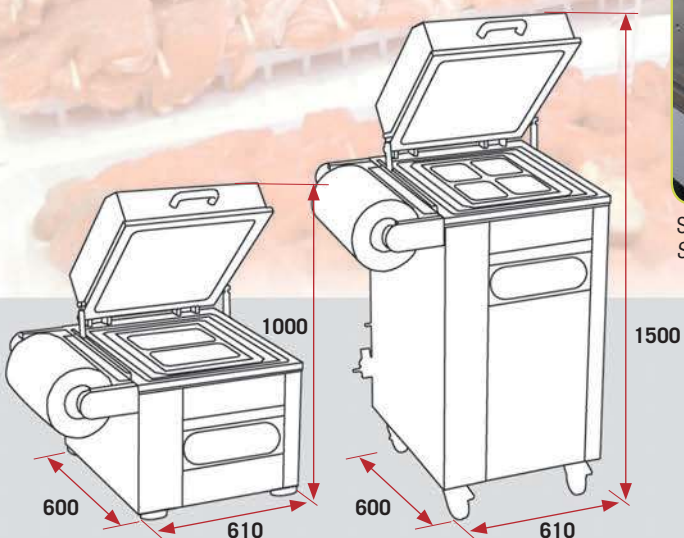

Saldatura a mezzo pistone pneumatico 3 ATA  
Sealing by pneumatic piston, 3 Ata



Fustellatura manuale delle vaschette  
Manual trays cutting

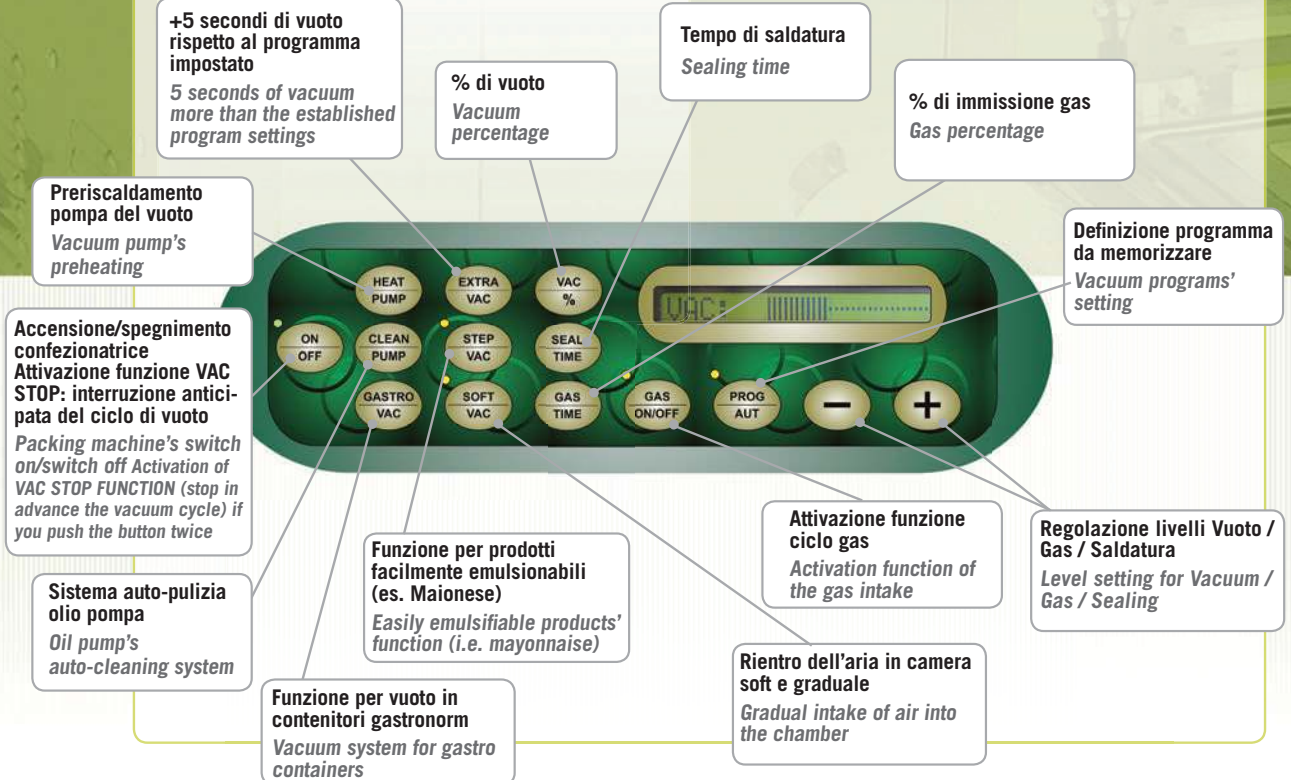

**PANNELLO COMANDI / control panel**

**STANDARD FUNCTIONS**

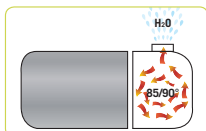
**Pannello multifunzione con sensore di vuoto**  
Vacuum sensor

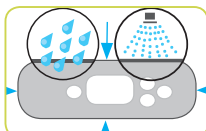

**Sistema autopulizia olio**  
Oil made auto cleaning system



**Pannello comandi a totale tenuta contro umidità**  
Waterproof control Panel



**Camera inox con angoli stondati senza saldature**  
Entirely printed stainless steel vacuum chamber, with internal round corners



**Piastra saldante idonea a qualsiasi formato di vaschetta**  
Sealing plate, suitable for every trays shape



**Predisposizione al gas inerte**  
Arrangement for idle gas

**OPTIONALS**

**Pompa rossa per ossigeno**  
Red pump for oxygen



**Stampi speciali**  
Special moulds



**Compressore**  
Compressor

IL NUOVO MONDO  
DELLA TERMOSIGILLATURA  
CON E SENZA VUOTO  
MADE IN LAVEZZINI

THE NEW WORLD  
OF TRAY-SEALING MADE  
IN LAVEZZINI WITH  
OR WITHOUT VACUUM





---

**ABBATTITORI DI TEMPERATURA**

**BLAST CHILLERS**

**CELLULES DE REFROIDISSEMENT**

**ABATIDORES DE TEMPERATURA**

**SCHNELLABKÜHLER**



LEGENDA SIMBOLI:



Costruito nel rispetto dell'ambiente  
*Environment friendly manufactured*  
*Construit en respectant l'environnement*  
*Fabricado respetando el ambiente*  
*Umweltfreundliche Herstellung*



Ideale per alimentari e gastronomie  
*Suitable for food shops and delicatessen*  
*Idéal pour alimentaires et gastronomies*  
*Ideal para detallantes y gastronomias*  
*Ideal für Lebensmittelverarbeitende Betriebe und Gastronomie*



Ideale per ristoranti  
*Suitable for restaurants*  
*Idéels pour restaurants*  
*Ideal para restaurantes*  
*Ideal für Restaurants*

FLASH Series PAG 86



FLASH 3  
FLASH 5  
FLASH 10



Polipropilene  
*Polypropylen*  
*Polypropylène*  
*Polipropileno*  
*Polypropylen*



Per teglie e griglie 60x40  
*For 60x40 pans and grids*  
*Pour plateaux et grilles 60x40*  
*Para bandejas y parrillas 60x40*  
*Für Bleche und Roste 60x40*



Per teglie e griglie GN  
*For GN pans and grids*  
*Pour plateaux et grilles GN*  
*Para bandejas y parrillas GN*  
*Für Bleche und Roste GN*





FLASH 3

60x40  
STANDARDGN  
STANDARD

Modello model modèles modelo Modelle	DIM. D'INGOMBRO overall dimension dim. d'encombrement dimensiones Abmessungen	DIMENSIONI INTERNE internal dimentions dimensions intérieures dimensiones internas Inneren Dimensionen	ABBATTIMENTO POSITIVO-RESA positive chilling - performance abbattement positif - durée abatimiento positivo - rendimiento Negative Abkühlung - Leistung	ABBATTIMENTO NEGATIVO- RESA negative chilling - performance abbattement négatif - durée abatimiento negativo - rendimiento Positive Abkühlung - Leistung	NUMERO TEGLIE (Non include) number of pans (not included) N° de plats (pas inclus) numero bandejas (no incluidas) Nummer der Auflaufformen (Nicht enthalten)
FLASH 3	750X740X720/750h	610X410X280h	+3° 14 kg	-18° 11 kg	3 - 1/1 GN - 3-60X40

DISTANZA TEGLIE pans distance distance des bacs distancia entre bandejas Distanz zwischen Backformen	CONTROLLO CICLO cycle control control du cycle de travail control ciclo Kontrolle des Arbeitszyklus	POTENZA ASSORBITA settled power Puissance installée potencia instalada Installierte Macht	TENSIONE voltage voltage tensión Spannung	PESO weight poids peso Gewicht	GAS REFRIGERANTE cooling gas gaz réfrigérant gas refrigerante Kühlgas
mm 70	ELECTRONIC	W 1150	230 V/50-60 Hz	KG 80	R 404A / R507

## FLASH 3



Semplice, compatto ed essenziale, l'abbattitore FLASH 3 risulta essere il connubio perfetto tra l'estrema facilità di utilizzo e una redditività di lavoro estremamente competitiva.

Impiegato nei più svariati settori di utilizzo: pasticcerie, gelaterie, ristoranti diverrà ben presto un insostituibile strumento di lavoro che consentirà una migliore organizzazione della giornata lavorativa.



Easy, compact and essential, blast chiller FLASH 3 is the best mix of an extreme facility and a very competitive job profitability. It is used in many sectors, such as: confectionery, ice-cream shops, restaurants, etc... and for sure it'll become an irreplaceable instrument helping you for a better job organization.



Simple, solide et essentiel, l'abattoir FLASH 3 est l'union parfaite entre la facilité d'utilisation et un rendement extrêmement compétitif. Cet abattoir est utilisé dans les secteurs les plus différents comme pâtisseries, glaceries, restaurants; ça deviendra en peu de temps un outil irremplaçable pour une meilleure organisation de votre journée de travail.



Sencillo, compacto y sobrio, el abatidor FLASH 3 es la unión perfecta entre facilidad de uso y rendimiento. Se utiliza en diferentes sectores: pastelerías, heladerías, restaurantes. Es un aparato indispensable para el trabajo y permite una mejor organización del día de trabajo.



Der Schockfroster FLASH 3 ist eine kompakte, essentielle und einfach zu benutzende Maschine. Es ist der Kompromiss zwischen Leichtigkeit und hoher Arbeitsrentabilität und wird in verschiedenen Bereichen benutzt: Konditorei, Eissalon, Restaurant und so weiter. Aus diesem Grund ist FLASH 3 ein unersetzliches Arbeitsinstrument, um eine bessere Betriebsorganisation zu planen.

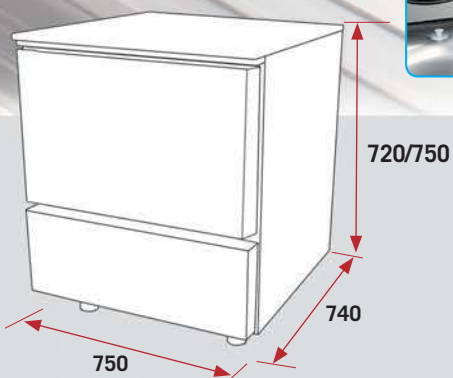

INOX | CE



FLASH 5

60x40  
STANDARDGN  
STANDARD

Modello model modèles modelo Modelle	DIM. D'INGOMBRO overall dimension dim. d'encombrement dimensiones Abmessungen	DIMENSIONI INTERNE internal dimentions dimensions intérieures dimensiones internas Inneren Dimensionen	ABBATTIMENTO POSITIVO-RESA positive chilling - performance abbattement positif - durée abatimiento positivo - rendimiento Negative Abkühlung - Leistung	ABBATTIMENTO NEGATIVO- RESA negative chilling - performance abbattement négatif - durée abatimiento negativo - rendimiento Positive Abkühlung - Leistung	NUMERO TEGLIE (Non include) number of pans (not included) N° de plats (pas inclus) numero bandejas (no incluidas) Nummer der Auflaufformen (Nicht enthalten)
FLASH 5	750X740X850/880h	610X410X410h	+3° 20 kg	-18° 15 kg	5 - 1/1 GN - 5-60X40

DISTANZA TEGLIE pans distance distance des bacs distancia entre bandejas Distanz zwischen Backformen	CONTROLLO CICLO cycle control control du cycle de travail control ciclo Kontrolle des Arbeitszyklus	POTENZA ASSORBITA settled power Puissance installée potencia instalada Installierte Macht	TENSIONE voltage voltage tensión Spannung	PESO weight poids peso Gewicht	GAS REFRIGERANTE cooling gas gaz réfrigérant gas refrigerante Kühlgas
mm 70	ELECTRONIC	W 1424	230 V/50-60 Hz	KG 95	R 404A / R507

## FLASH 5



Questo modello di abbattitore rappresenta di certo il giusto compromesso tra un'importante capienza interna (5 teglie) che vi consentirà di "abbattere" svariate tipologie di prodotto (sughi, carni, prodotti dolciari etc...) in tempi ristretti ed un posizionamento di mercato davvero competitivo. Grazie a questo pregevole rapporto qualità - prezzo FLASH 5 trova applicazione in differenti ambiti lavorativi: ristoranti, gastronomie, gelaterie, etc...

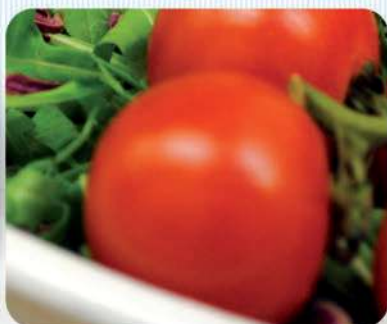

This model of blast chiller represents the right compromise between an important internal capacity (5 pans) able to "chill" several kind of products very fast (meat, sauces, sweets etc...) and a competitive market position. Thanks to this high quality-price relation FLASH 5 finds the applications in several fields: restaurants, ice - cream shops, delicatessen, etc...



Ce modèle d'abattoir représente sans doute le juste équilibre entre une large capacité interne (5 moules) que vous donnera la possibilité de refroidir plusieurs typologies de produits (sauces, viande, confiserie...) dans peu de temps et de vous présenter sur le marché avec des prix très compétitifs. Grace à cet excellent rapport entre qualité et prix FLASH 5 peut être utilisé dans différents domaines: restaurants, gastronomies, glaceries...



Este modelo de abatidor es la fusión entre una buena capacidad (5 bandejas) y una colocación en el mercado verdaderamente competitiva. Se pueden abatir diferentes productos (salsas, carnes, dulces...). Debido a esta óptima relación precio - calidad, FLASH 5 se utiliza en diferentes sectores: restaurantes, gastronomías, heladerías...



Diese Maschine hat eine große Kapazität (5 Auflaufformen), die verwendet wird, um verschiedene Produkte (Fleisch, Süßigkeiten, Saucen...) abzukühlen. FLASH 5 hat auch einen wettbewerbsfähigen Preis. Durch diesen Aspekten kann FLASH 5 in vielen Arbeitsbereichen genutzt werden: Restaurants, Konditoreien, Eissalons ...

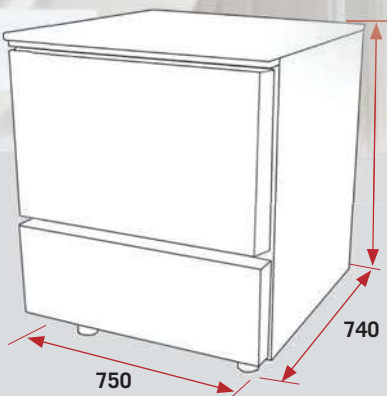

850/880

740

750



INOX | CE



FLASH 10

60x40  
STANDARDGN  
STANDARD

Modello model modèles modelo Modelle	DIM. D'INGOMBRO overall dimension dim. d'encombrement dimensiones Abmessungen	DIMENSIONI INTERNE internal dimensions dimensions intérieures dimensiones internas Inneren Dimensionen	ABBATTIMENTO POSITIVO-RESA positive chilling - performance abbatement positif - durée abatimiento positivo - rendimiento Negative Abkühlung - Leistung	ABBATTIMENTO NEGATIVO- RESA negative chilling - performance abbatement négatif - durée abatimiento negativo - rendimiento Positive Abkühlung - Leistung	NUMERO TEGLIE (Non include) number of pans (not included) N° de plats (pas inclus) numero bandejas (no incluidas) Nummer der Auflaufformen (Nicht enthalten)
FLASH 10	750X740X1260/1290h	610X410X760h	+3° 25 kg	-18° 20 kg	10 - 1/1 GN - 10-60X40

DISTANZA TEGLIE pans distance distance des bacs distancia entre bandejas Distanz zwischen Backformen	CONTROLLO CICLO cycle control control du cycle de travail control ciclo Kontrolle des Arbeitszyklus	POTENZA ASSORBITA settled power Puissance installée potencia instalada Installierte Macht	TENSIONE voltage voltage tensión Spannung	PESO weight poids peso Gewicht	GAS REFRIGERANTE cooling gas gaz réfrigérant gas refrigerante Kühlgas
mm 70	ELECTRONIC	W 1490	230 V/50-60 Hz	KG 80	R 404A / R507

## FLASH 10



Quando l'abbattitore costituisce un elemento imprescindibile del vostro luogo di lavoro, FLASH 10 è la soluzione ideale per le vostre esigenze di abbattimento. Infatti questa tipologia di abbattitore, grazie ad un'elettronica completa ed estremamente precisa, unitamente ad una capienza interna davvero importante, permette di essere impiegato in centri cottura, laboratori di produzione, pasta fresca, pasticceria, panificazione...



If the blast chiller is the most important element in your job, FLASH 10 is the ideal solution for your needs. For this reason, thanks to complete and precise electronics, plus an important internal capacity, it can be used in production laboratories, fresh pasta, bakeries, confectioneries...



Quand l'abattoir représente un élément essentiel de votre travail, FLASH 10 est la solution idéale pour vos exigences de réfrigération. Ce type d'abattoir a un circuit électronique complète et extrêmement précis ainsi qu'une capacité interne vraiment vaste et permet son utilisation dans des centres de cuisson, laboratoires de production de pâtes fraîches, pâtisseries, fabrication de pain...



Quando el abatidor es indispensable para el trabajo diario, FLASH 10 representa la solución ideal para sus necesidades de abatimiento. De hecho este abatidor, gracias a una electronica completa y muy fiable junto a una gran capacidad interna, puede utilizarse en centros de cocción, obradores, pastelerías, pasta fresca, panificación...



Wenn der Schockfroster ein wichtiges Element Ihrer Arbeit ist, ist FLASH 10 die ideale Lösung. Durch die komplette und sorgfältige Elektronik und eines inneren Fassungsvermögen, können Sie FLASH 10 in verschiedenen Bereichen verwenden: Produktionslaboratorium, Konditorei, Brotbaken...

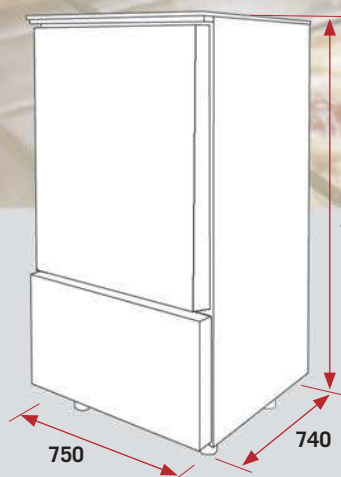

1260/1290

750

740

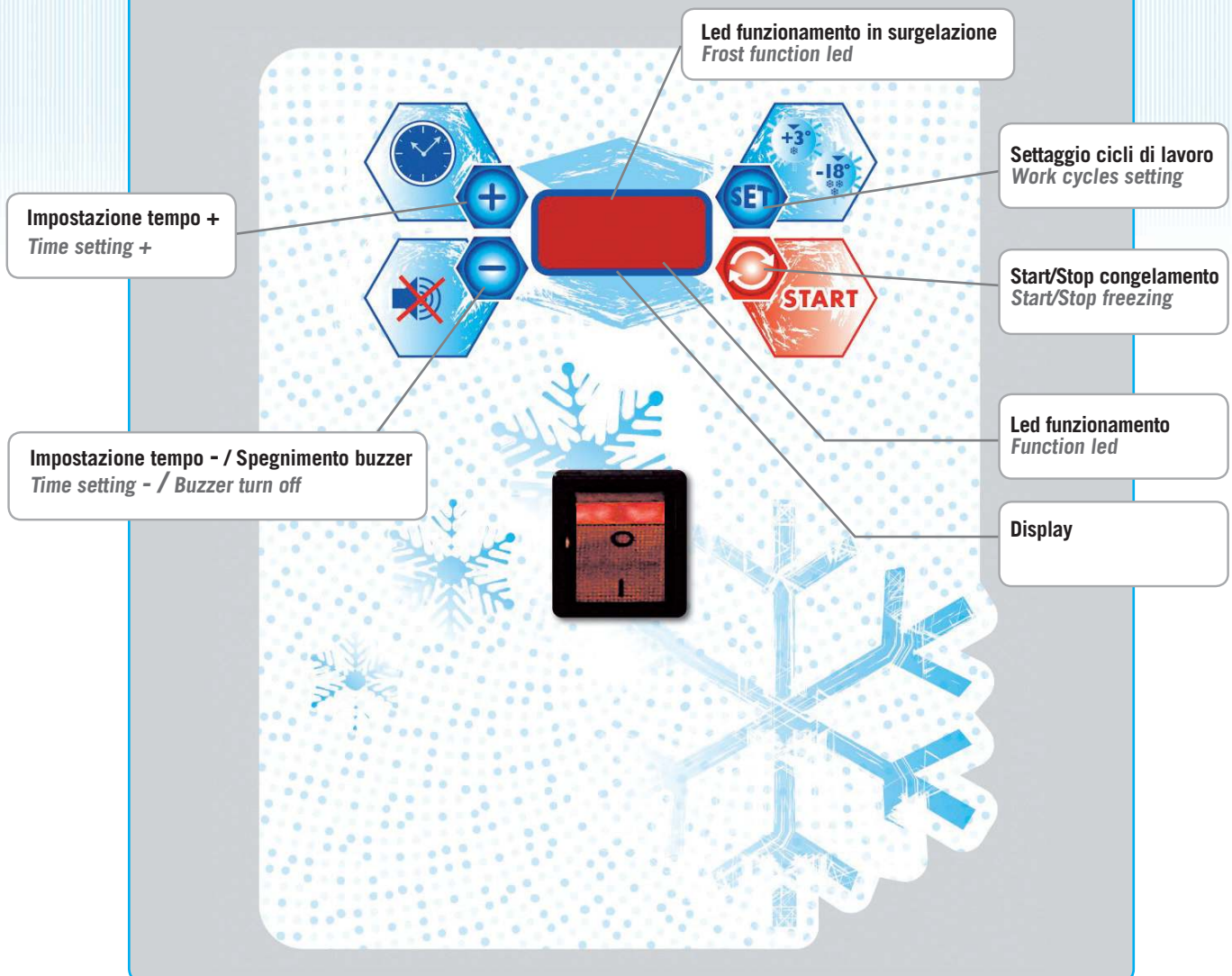

NOX|CE

**PANNELLO COMANDI / control panel**

## STANDARD FUNCTIONS

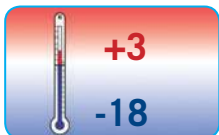

**Ciclo di abbattimento positivo / negativo**  
*Positive and negative blast chilling*



**Sonda di rilevamento temperature al cuore**  
*Drill for temperature in the heart of the product*



**Struttura porta teglia idonea per: teglie gastronomia e pasticceria**  
*Tray caddy structur for: delicatessen and confectionery*



**Guarnizione della porta pre-riscaldata**  
*Pre heating door gasket*



**Sonda camera**  
*Room probe*



**Teglia raccolta liquidi per attività di scongelamento**  
*Tray for liquid points during the defreezing activity.*

## OPTIONALS AND COMPLEMENTS



**Teglie per gastronomia di differenti misure**  
*Gastronorm pans with different sizes*



**Teglie per pasticceria di differenti misure**  
*Pastry pans with different sizes*



**Contenitore con doppio fondo per pesce in Polipropilele trasparente 530x325xh150**  
*Polypropylene false bottom container for fish 530x325xh150*



**Griglia plastificata 530x325**  
*Plastic-coated grid 530x325*



**Griglia plastificata pasticceria 60x40**  
*Plastic-coated pastry grid 60x40*

Web [www.lavezzini.it](http://www.lavezzini.it)

@ [info@lavezzini.it](mailto:info@lavezzini.it)

+39 0523 244011

+39 0523 244049

lavezzini01

LAVEZZINI srl - advanced vacuum system

Lavezzini srl vacuum packaging

LAVEZZINI NEL MONDO CON IL BASKET...



Nel mondo anche con lo sport  
*In the world with sport too*

IL BASKET NEL MONDO CON LAVEZZINI



LAVEZZINI IN THE WORLD WITH BASKET...  
...THE BASKET WORLD WITH LAVEZZINI



---

ADVANCED VACUUM SYSTEM

Via Maestri del Lavoro d'Italia, 24  
29017 Fiorenzuola d'Arda (PC) ITALY  
Tel. +39.0523.244011  
Fax +39.0523.244049  
[http: www.lavezzini.it](http://www.lavezzini.it)  
e-mail: [info@lavezzini.it](mailto:info@lavezzini.it)  
Skype: lavezzini01